

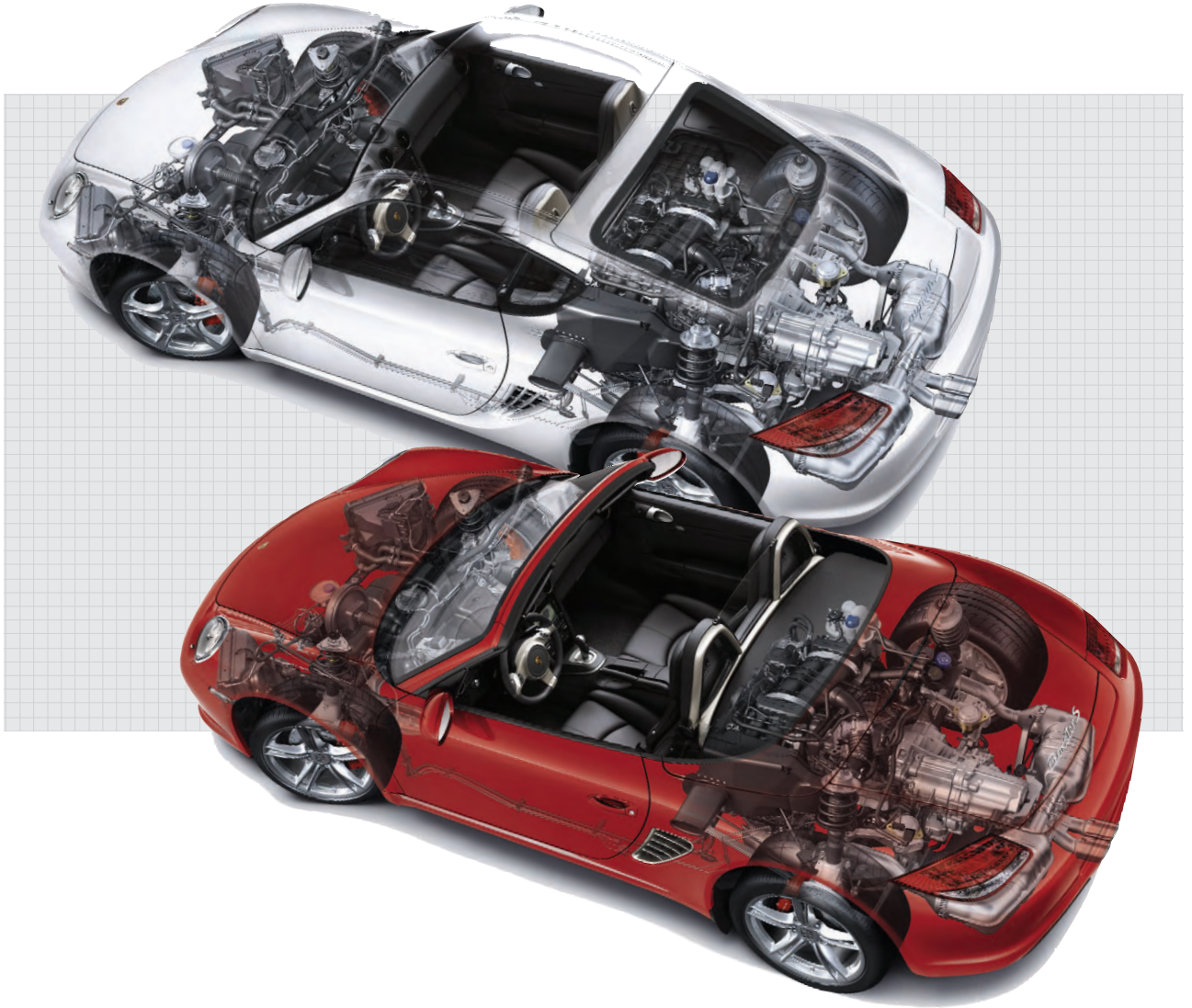

PORSCHE



Service Information

2009 Technik Introduction

All Boxster/Cayman Models

Important Notice: Some of the contents of this AfterSales Training brochure was originally written by Porsche AG for its rest-of-world English speaking market. The electronic text and graphic files were then imported by Porsche Cars N.A, Inc. and edited for content. Some equipment and technical data listed in this publication may not be applicable for our market. Specifications are subject to change without notice.

We have attempted to render the text within this publication to American English as best as we could. We reserve the right to make changes without notice.

© 2009 Porsche Cars North America, Inc. All Rights Reserved. Reproduction or translation in whole or in part is not permitted without written authorization from publisher. AfterSales Training Publications

Dr. Ing. h.c. F. Porsche AG is the owner of numerous trademarks, both registered and unregistered, including without limitation the Porsche Crest®, Porsche®, Boxster®, Carrera®, Cayenne®, Cayman™, Panamera®, Tiptronic®, VarioCam®, PCM®, 911®, 4S®, FOUR, UNCOMPROMISED.SM and the model numbers and distinctive shapes of Porsche's automobiles such as, the federally registered 911 and Boxster automobiles. The third party trademarks contained herein are the properties of their respective owners. Specifications, performance standards, options, and other elements shown are subject to change without notice. Some vehicles may be shown with non-U.S. equipment. Porsche recommends seat belt usage and observance of traffic laws at all times. Printed in the USA

Foreword

Since its North American launch in 1997, “Boxster” has quickly become synonymous with the ultimate in roadster feeling. Together with the Cayman launched in 2006, it is successfully continuing the Porsche tradition of roadsters and coupés that started over 50 years ago with the legendary 356 and 550 Spyder models.

The 2nd generation of the 987 Boxster and Cayman also incorporates the latest developments and technologies.

As usual, this Technical Service Information provides an overview of all the changes and innovations such as the brand new generation of engines with direct fuel injection (DFI; S models). The performance figures have once again been enhanced while keeping the displacement the same and the power output and torque values of the Cayman have been improved over those of the Boxster.



You can also learn all the details about the completely new Porsche Doppelkupplung (PDK) with 7 gears, redesigned Porsche Communication Management (PCM) and air-conditioned seats, which are now also available to offer superior driving comfort for the Boxster S and Cayman S.



Content

1 Engine

General information	3
Technical data	4
Crankcase	7
Crankshaft/crankshaft bearings	9
Connecting rods	10
Pistons	11
Belt drive	12
Cylinder head	14
Camshafts	16
Chain drive	17
VarioCam Plus	18
Vacuum pump	19
Fuel high-pressure pump	19
Positive crankcase ventilation	19
Oil supply	20
Cooling	23

2 Fuel and ignition system (DME)

General information	27
3.4-liter engine with DFI	28
DFI characteristics	32
DME control unit EMS SDI 3.1	34
Hot-film mass air flow sensor MAF 7	38
Low-pressure fuel supply	39
High-pressure fuel system	41
Ignition system	49
Air routing on intake side	51
Exhaust system, emission control	53
2.9-liter engine with MPI	57
DME control unit ME 7.8.2	58
Intake system	59
Fuel injectors EV14	59
Exhaust system	60

3 Porsche Doppelkupplung (PDK)

General information	64
Transmission data	65
Transmission oils	66

Boxster
Boxster S
Cayman
Cayman S



Boxster
Boxster S
Cayman
Cayman S

Transmission

3

3 Porsche Doppelkupplung (PDK) Cont'd)

Transmission concept	68
Operation	69
3-spoke sports steering wheel for PDK	70
Gearshift strategy	72
Special functions	75
Basic transmission	80
Synchronization	83
Final drive with differential	86
Shifting	87
Parking lock	88
Power flow	89
Double clutch	90
Hydraulic control	93
Sensors	97
Electronic transmission control	102
Manual transmission	103

Chassis

4

4 Chassis 107

General information	107
Front axle	108
Rear axle	110
Porsche Active Suspension Management	111
Wheels and tires	112
Tire Pressure Monitoring (2nd generation)	114
Brake system	119
Porsche Stability Management (PSM)	120

Body

5

5 Body 125

Boxster, Boxster S, General information	125
Bodyshell	126
Cayman, Cayman S, General information	127
Bodyshell	128

Exterior body equipment

6

6 Exterior body equipment 129

Boxster, Boxster S, Exterior body equipment	129
Cayman, Cayman S, Exterior body equipment	135

7 Interior body equipment

General information	141
Steering wheel	142

8 Heating and air conditioning

Externally controlled compressor	145
Air-conditioned seats	151
Heated steering wheel	155

9 Electrics and electronics

General information, lights	157
Main headlights, front light module	158
Bi-Xenon, headlight	159
Speed and swivel angle	162
Tail lights	162
Instruments, instrument cluster	165
Shift indicator	166
Audio and communication, CDR-30	167
Porsche Communication Management	169
Touchscreen and operating logic	171
Operating principles of PCM	173
Audio	173
Navigation module	174
Electronic logbook	176
Telephone module	177
Mobile phone preparation	178
Cordless handset	179
Voice control	179
CD/DVD changer	180
BOSE® Surround Sound System	180
Audio interface	182
TV tuner, satellite radio	183
Sport Chrono Package Plus	184

Interior body equipment

7

Heating and air conditioning

8

Electrics and electronics

9



1 Engine

General information

All new Boxster and Cayman models, as with the new 911, use a completely new generation of engines with significantly higher performance figures. The displacement of the completely new flat engine has been increased from 2.7 liters to 2.9 liters to achieve an increase in power output of 10 bhp to 225 bhp (188 kW) for the Boxster and 20 bhp to 265 bhp (195 kW) for the Cayman. In combination with the new standard 6-speed manual transmission, the basic versions now accelerate from 0 to 62 mph (100 km/h) in under 6 seconds.

The power output of the new S models has increased by 15 bhp to 310 bhp (228 kW) for the Boxster S and by 25 bhp to 320 bhp (235 kW) for the Cayman S, while the displacement has stayed the same at 3.4 liters. This increase is mainly due to direct fuel injection (DFI).

The Cayman models have higher power output and torque values compared to the Boxster models. The result is better performance figures, which confirm the superior positioning of the Cayman models with regard to driving dynamics potential.

Boxster
Boxster S
Cayman
Cayman S

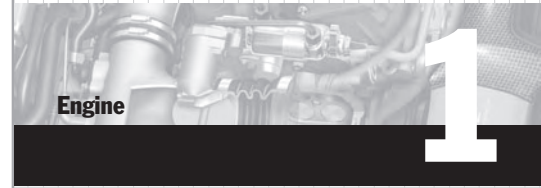

General information	3	VarioCam Plus	18
Technical data	4	Vacuum pump	19
Crankcase	7	Fuel high-pressure pump	19
Crankshaft/crankshaft bearings	9	Positive crankcase ventilation	19
Connecting rods	10	Oil supply	20
Pistons	11	Cooling	23
Belt drive	12		
Cylinder head	14		
Camshafts	16		
Chain drive	17		

Boxster
Boxster S
Cayman
Cayman S

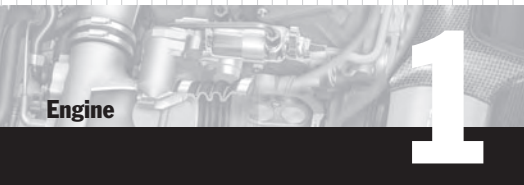

Engine

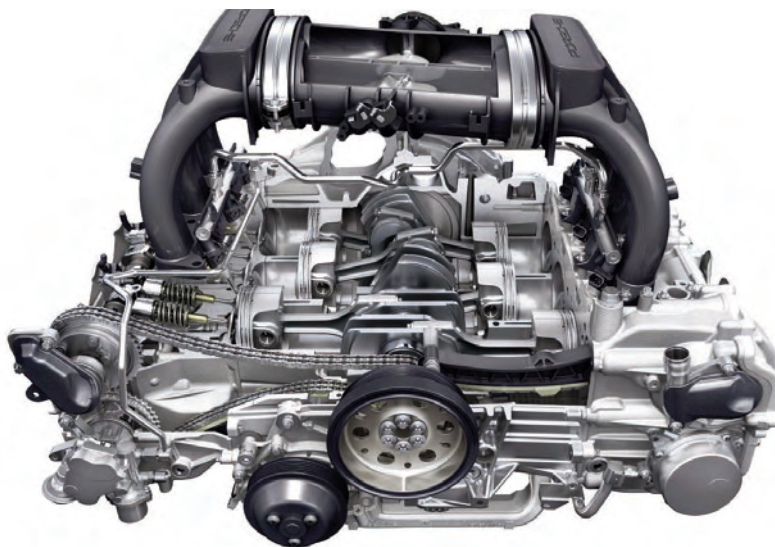

01_30_09

Technical data

	Boxster	Boxster S	Cayman	Cayman S
Engine type	MA120	MA121	MA120C	MA121C
No. of cylinder	6	6	6	6
Valves/cylinder	4	4	4	4
Displacement	2893 cc	3436 cc	2893 cc	3436 cc
Bore	89 mm	97 mm	89 mm	97 mm
Stroke	77,5 mm	77,5 mm	77,5 mm	77,5 mm
Engine power	188 kW/ 255 bhp	228 kW/ 310 bhp	195 kW/ 265 bhp	235 kW/ 320 bhp
at engine speed	6400 rpm	6400 rpm	7200 rpm	7200 rpm
Max. torque	290 Nm	360 Nm	300 Nm	370 Nm
at engine speed	4400 - 6000	4400 - 5500	4400 - 6000	4750
Compression	11,5	12,5	11,5	12,5
Governed speed	7500 rpm	7500 rpm	7500 rpm	7500 rpm

Boxster
Boxster S
 Cayman
 Cayman S

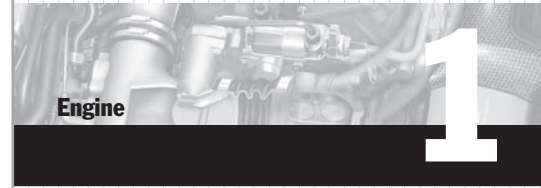

Boxster power/torque diagram

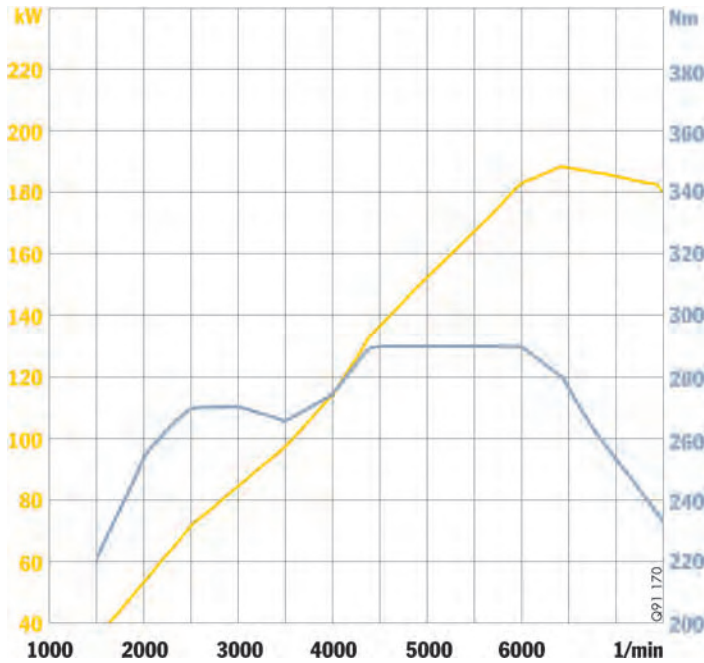

01_31_09

Boxster S power/torque diagram

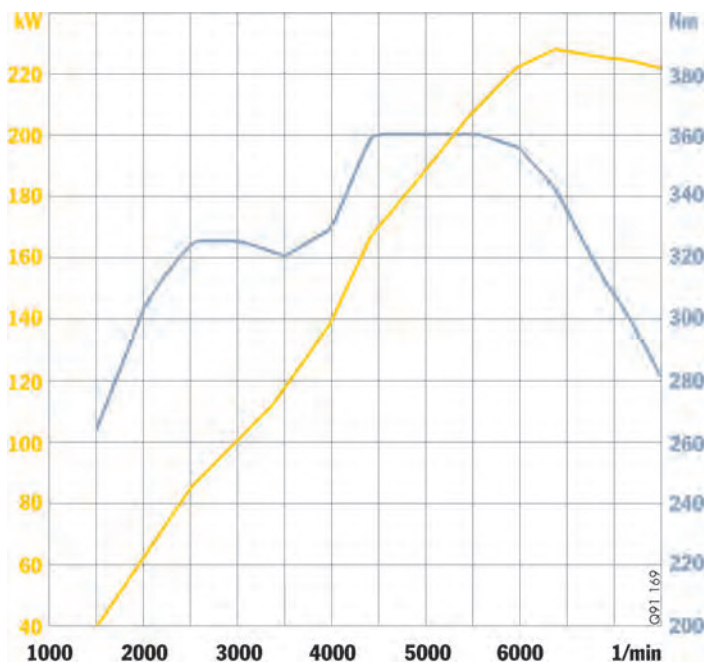

01_32_09

Engine type MA120
 Displacement 2,893 cc
 Power output 188 kW/255 bhp
 at engine speed 6,400 rpm

Engine type MA121
 Displacement 3,436 cc
 Power output 228 kW/310 bhp
 at engine speed 6,400 rpm

Boxster
Boxster S
Cayman
Cayman S

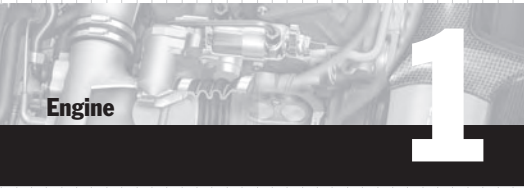

Engine

Engine type MA120C
 Displacement 2,893 cc
 Power output 195 kW/265 bhp
 at engine speed 7,200 rpm

Cayman power/torque diagram

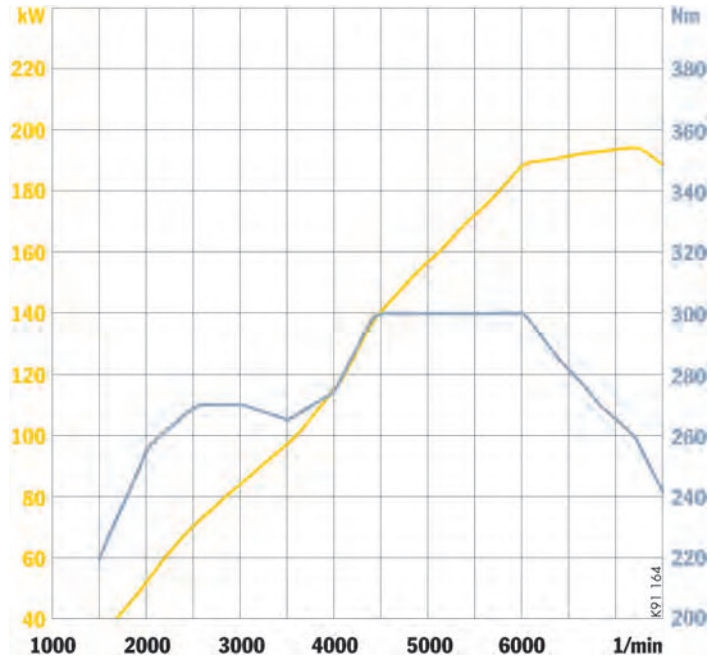

1_33_09

Engine type MA121C
 Displacement 3,436 cc
 Power output 235 kW/320 bhp
 at engine speed 7,200 rpm

Cayman S power/torque diagram

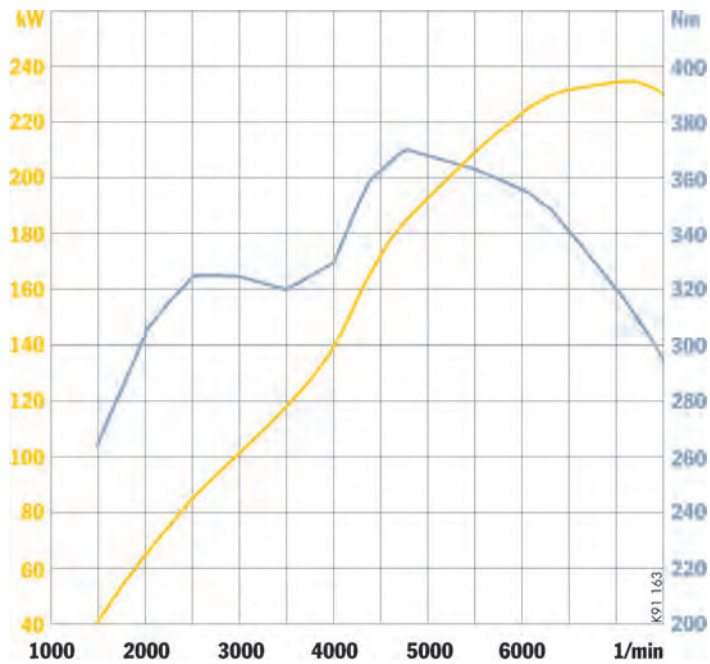

1_34_09

Crankcase

The new Boxster and Cayman engines, like the 911 models, feature a two-part, vertically split crankcase with integrated crankshaft thrust blocks.

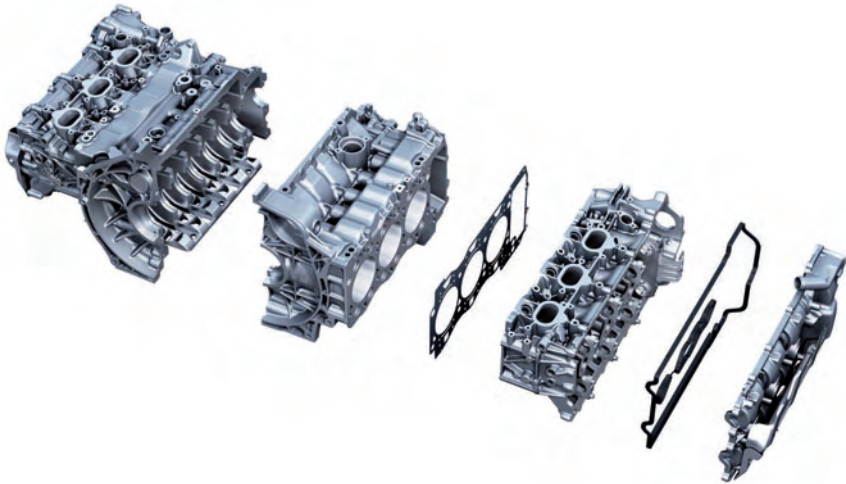

1_05_09

The actual crankcase is made completely of an aluminum-silicon alloy (ALUSIL).

This method offers the following advantages:

- With ALUSIL, the crankcase can be made from one cast, without cylinder sleeves and without having to coat the cylinder bores afterwards.
- ALUSIL is an excellent heat conductor and thus allows high specific engine output values.
- ALUSIL has excellent friction properties. Since the pistons and piston rings slide on the exposed silicon crystals, they have a low tendency to seize.
- ALUSIL does not present any recycling problems because the crankcase does not include any foreign materials, e.g. cast-in cast iron cylinder liners.

The listed advantages of the alloy are certainly important arguments in its favor. Indeed, the low-pressure chill-casting procedure, which has since proved to be the best solution by far for casting ALUSIL, is an important prerequisite for reliable, mass-produced cast crankcase parts.

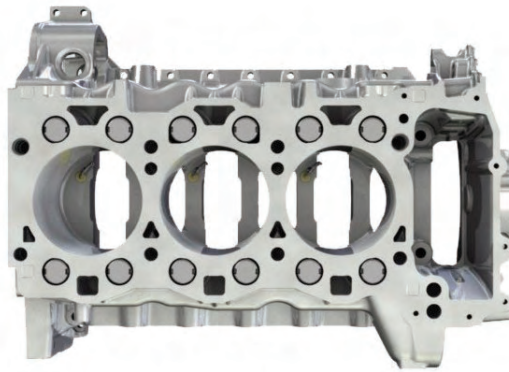

1_35_09

Cylinders are now connected differently in the cylinder-head cover area, as on the 911 models. The individual cylinders, which originally stood freely in the water jacket (open deck design), are now connected by a closed cylinder deck (closed deck design). The advantage of this design is high cylinder stability, particularly with regard to the cylinder shape (roundness and low cylinder deformation) over a wide load and temperature range. This has the added advantage of reducing friction and thus lowering fuel consumption. Even piston and piston-ring sealing has been improved as a result of the enhanced retention of roundness of the cylinders, which means a reduction in the blow-by gases that can flow into the crankcase during combustion. Conversely, the entry of oil from the crankcase into the combustion chamber is reduced, thus also lowering oil consumption.



Crankshaft/crankshaft bearings

The drop-forged crankshaft runs on eight bearings and has twelve counterweights. Main bearing 4 is designed as a thrust bearing. Axial play is determined by two thrust plates, which are inserted at the left and right of the bearing.

The main bearings are designed as plain bearings with a diameter of 63 mm. Main bearings 1/3/5/7/8 are smooth bearings, while main bearings 2/4/6 are grooved bearings. These grooved bearings supply oil to the connecting-rod bearings.

The drive mechanism for the two drive chains for the camshafts and demand-controlled oil pump is located on the pulley side.

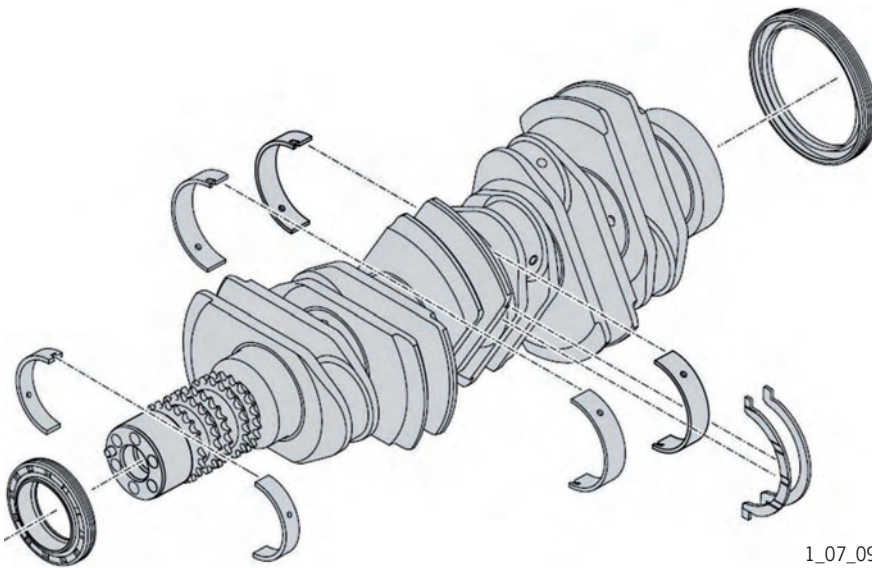

1_07_09

- 1 Plain compression ring
- 2 Stepped taper-faced ring
- 3 Oil scraper ring
- 4 Piston
- 5 Hook circlip
- 6 Connecting rod
- 7 Connecting rod bearing shell
- 8 Piston pin

Connecting rods

The connecting rods (6) are forged and are split (cracked) at the big end following machining. Both parts are aligned with one another via the fractured surface. Although a matching number is not needed for cracked connecting rods because of the fact that each fractured surface has a different shape, matching numbers are used here to ensure process reliability. During fitting, it is important to ensure that this matching number is facing upwards. The connecting rods are 140 mm long.

The piston-pin circlips are secured with twist locks and have an additional hook for removal.

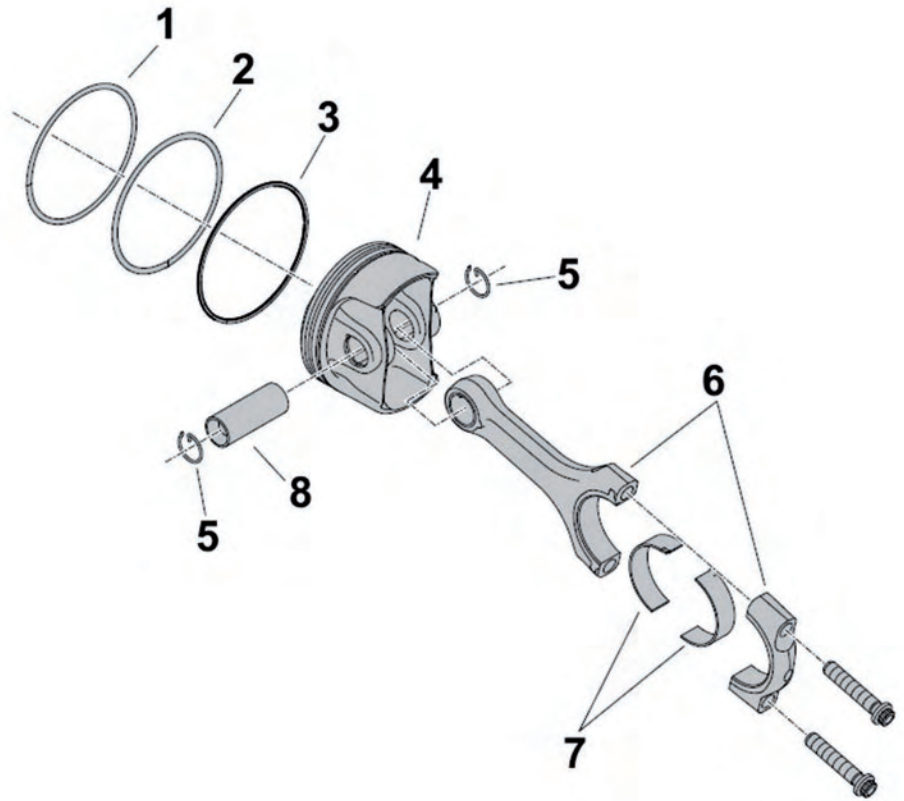

1_08_09

Pistons

The pistons on the new Boxster and Cayman models are forged from a light alloy. Since mixture formation is different on the basic models and the S version, the piston shape is also different.

Mixture formation and the direct fuel injection (DFI) combustion process require a special piston crown shape. The piston crown is a relatively large part of the combustion chamber and has a major influence on efficient combustion. Its shape also affects mixture formation and fresh fuel-air mixture stabilization in the spark plug area during injection processes in the compression phase in particular.

The pistons of the basic models have a conventional design.

Piston cooling

The piston crown temperature in the Boxster and Cayman engines is reduced by means of piston injection cooling. The spray nozzles are force-fitted in the crankcase. To ensure the necessary engine oil pressure at low revs and high engine oil temperatures, these spray nozzles only open at a higher oil pressure.



1_10_09

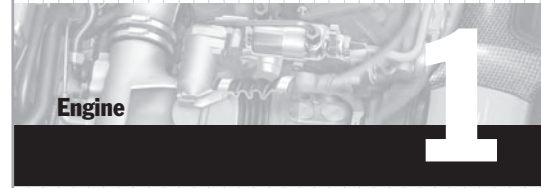

1_36_09

Belt drive

The belt drive in the new Boxster and Cayman engines has been improved compared to previous models through the following measures in particular:

- Double-sided poly-V-belt
- Light-alloy torsional vibration damper
- Maintenance-free hydraulic belt tensioner



1_37_09



1_12_09

The use of a 6-groove dual poly V-belt makes it easier to drive the auxiliary units. As a result, two deflection rollers used on the previous models are no longer needed, thereby reducing the weight and torsional mass. The use of plastic pulleys (on auxiliary units) and a new torsional vibration balancer with improved dynamic properties also reduces the weight and torsional mass.

Markings and fixing bores have been applied to the pulley and crankcase to facilitate various maintenance and repair work (see picture 1_12_09).

Belt tensioner

The new maintenance-free, hydraulic belt tensioner with its speed-proportional damping minimises the belt vibrations on the bearings in the system.

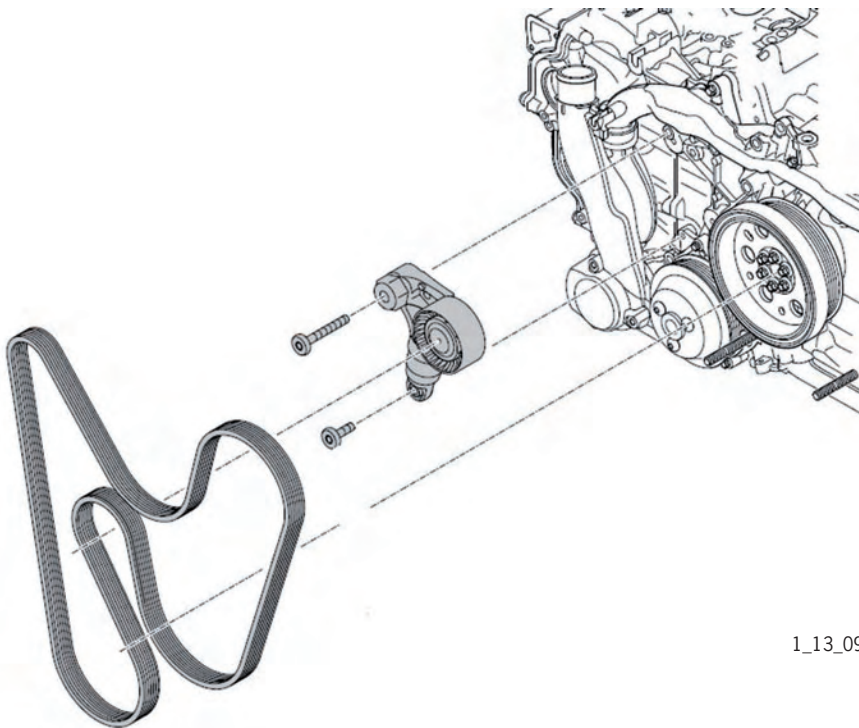

1_13_09



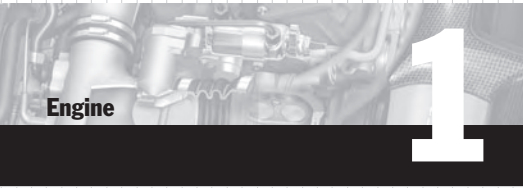

1_38_09

- 1 Exhaust valve (Ø basic 29.9 mm, S models Ø 34.2 mm)
- 2 Valve-seat ring, exhaust
- 3 Intake valve (Ø basic 34.4 mm, S models Ø 39.5 mm)
- 4 Valve-seat ring, intake
- 5 Valve guide
- 6 Valve-spring plate
- 7 Valve-stem seal
- 8 Valve spring, intake (inner)
- 9 Valve spring, intake (outer)
- 10 Valve-spring plate
- 11 Valve guide
- 12 Valve-spring plate
- 13 Valve-stem seal
- 14 Valve spring, exhaust (inner)
- 15 Valve spring, exhaust (outer)
- 16 Valve-spring plate

Cylinder head

The cylinder heads in the new engines are designed as a single piece without a separate housing for the hydraulic bucket tappets. It was possible to reduce the weight of the new cylinder heads compared to the previous models (two-piece cylinder heads with a separate bucket tappet guide housing) by using an improved casting process.

Also on the new Boxster and Cayman models, the intake ports and valve-seat rings have been designed for optimised flow and production based on extensive simulations and form the basis for achieving high specific power output and torque values. The intake and outlet camshafts have also been re-adjusted for improved gas exchange. This allows both high maximum torque and power output values as well as high torque even at low engine speeds.

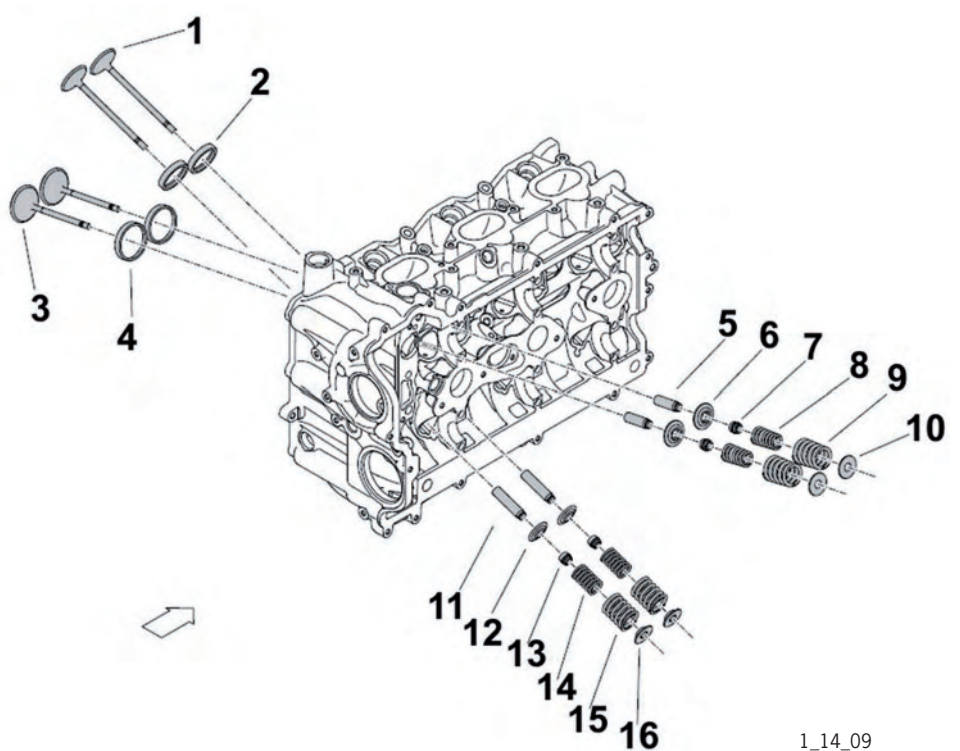

1_14_09



Cylinder-head gasket

To ensure the excellent sealing quality of the surface of the multi-layer steel seal, it is covered with high temperature-resistant plastic. The advantage of this steel seal is that the heat can be conducted very well away from the cylinder head.

Camshaft bearing

The camshafts are guided directly in the cylinder head by means of individual bearing saddles in the bearing seat. The camshaft bearings at the chain box are designed as bearing saddles. To avoid confusion, the bearing saddles are stamped with the matching numbers and the letters "E" for intake and "A" for exhaust.

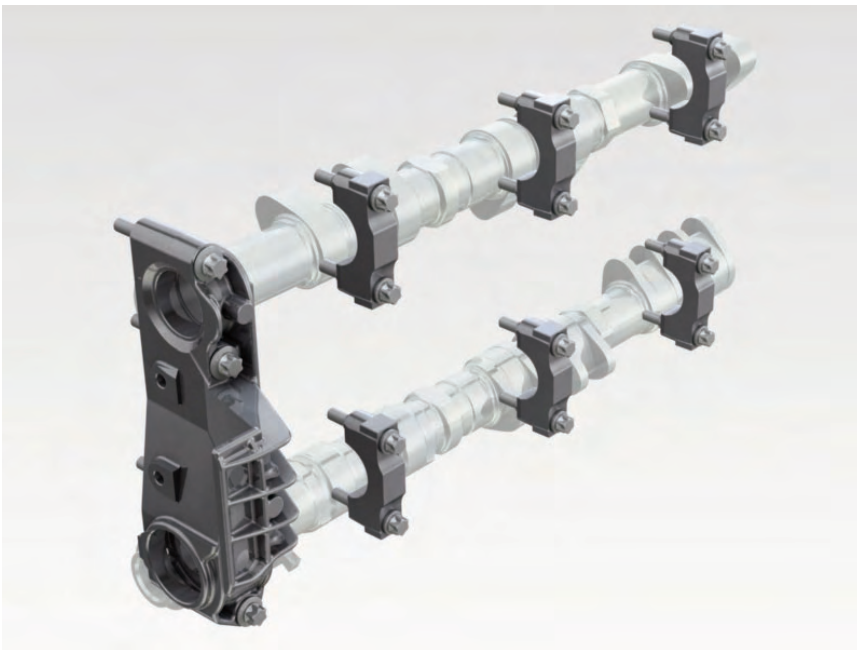

1_39_09

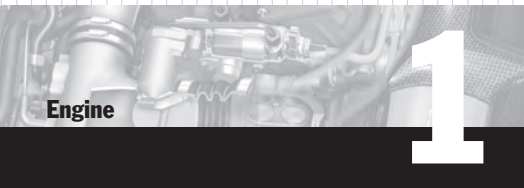

Engine

Cylinder head cover

The cylinder head cover is a separate part made of light alloy. To ensure excellent sealing, a moulded elastomer seal is fitted between the cylinder head and cylinder head cover.

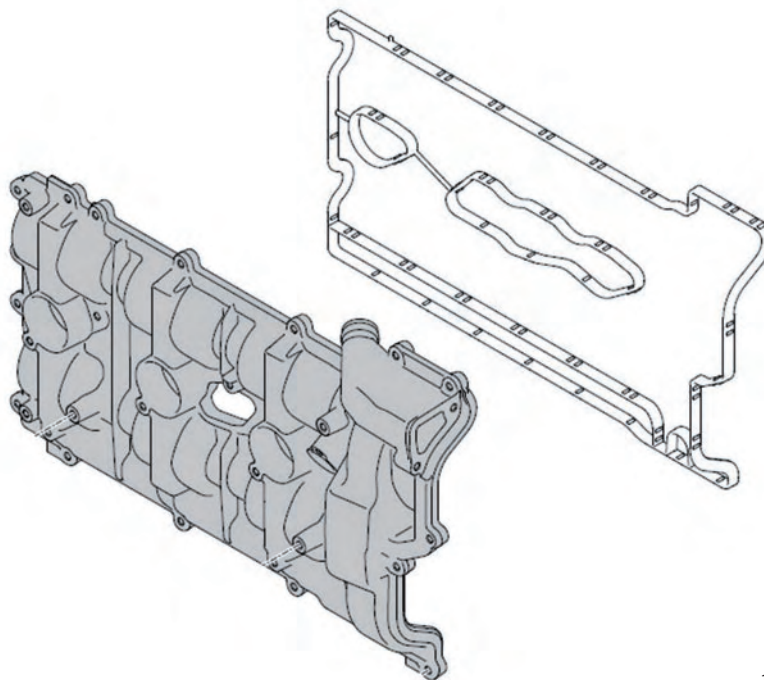

1_16_09

Camshafts

The exhaust and intake camshafts are hollow-cast from chilled cast iron and are driven directly by the crankshaft via one duplex sleeve-type chain each. On the 2.9-liter engines, the intake valve lift is 3.6 mm (small) and 10.0 mm (large). On the 3.4-liter engines, the small valve lift is the same as on the 2.9-liter engines, while the large valve lift is 10.5 mm.

The exhaust valve lift is 9.7 mm on the 2.9-liter engine and 10.35 mm on the 3.4-liter engine.

The timing for both engines is as follows:

	2.9-liter engines	3.4-liter engines
Intake opens, large stroke, late	18° after top dead centre (TDC)	19° after TDC
Intake closes, large stroke, late	45° after bottom dead centre (BDC)	62° after BDC
Intake opens, small stroke, late	38.5° after TDC	44° after TDC
Intake closes, small stroke, late	18.5° before BDC	14° before BDC
Exhaust opens	34.5° before BDC	40° before BDC
Exhaust closes	0.5° after TDC	3° after TDC

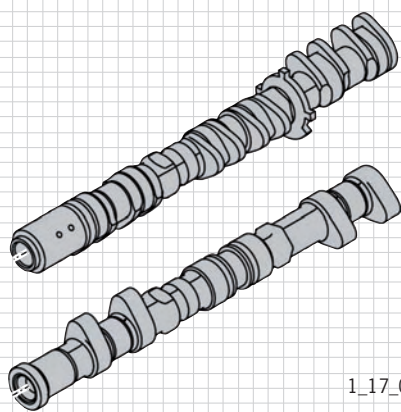

1_17_09



Chain drive

Another special feature of the new generation of engines is that these engines no longer have an intermediate shaft. This drive shaft, which was fitted between the crankshaft and the camshafts on previous models, was required in order to reduce the transmission ratio and thus the dynamic forces of the timing chains. Through the use of new, high-performance timing chains, it was possible to simplify the drive mechanism for the camshafts in spite of higher revs, thereby reducing the weight of the engine significantly by removing the intermediate shaft. Together with an additional crankshaft bearing location, this allows greater stability and a significantly higher engine speed potential.



1_40_09

Timing drive mechanism

The two timing chains are controlled by guide and tensioning rails. Two hydraulic chain tensioners connected to the engine oil circuit ensure the required tensioning of both chains.

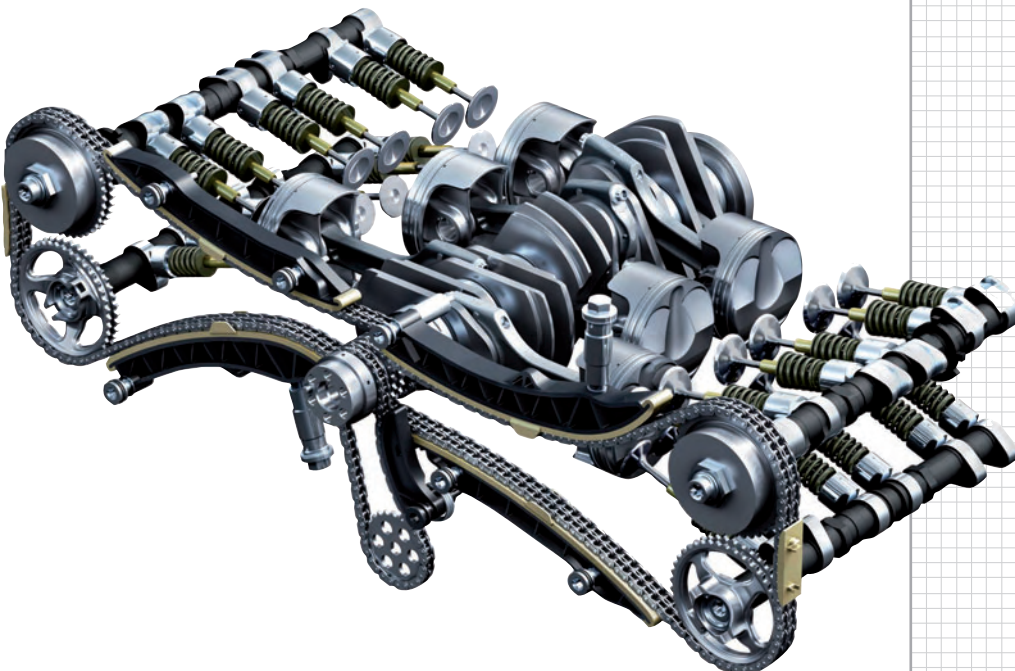

1_18_09

Camshaft control with valve-lift adjustment (VarioCam Plus)

The requirements imposed on engine design with regard to customer requests for higher performance combined with improved driving comfort, compliance with statutory emissions limits and reduced fuel consumption give rise to conflicting design criteria. The development of VarioCam Plus was therefore based on the idea of producing a variable engine, which can be optimised for maximum performance and also for regular driving in city traffic or on secondary roads. This requires a control system for the intake camshaft to vary the opening and closing times in combination with a valve lift system.

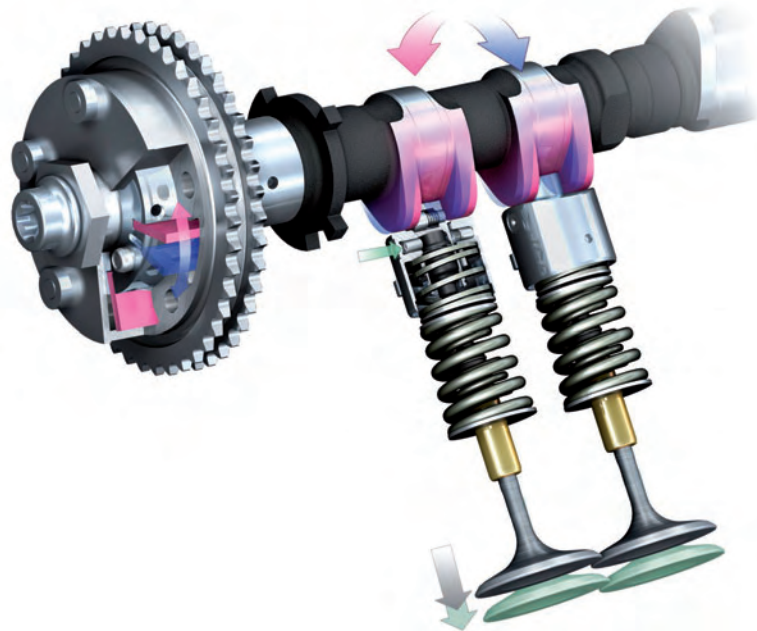

09

Camshaft actuator

The camshaft control principle is based on the principle of a vane controller. The adjustment range is 40° crank angle. The control unit determines the current position of the camshaft in relation to the crankshaft (actual angle) on the basis of the speed sensor signal and the Hall sender signal. The position control in the control unit receives the desired nominal angle via the programmed map values (speed, load, engine temperature). A regulator in the Motronic unit activates the electrohydraulic control valve according to the desired adjustment when there is a difference between the nominal angle and actual angle.



Vacuum pump

The Boxster and Cayman models use a higher-performance mechanical vacuum pump to provide the vacuum for the brake booster and various vacuum valves. Its familiar rotary vane technology as well as its outer position on cylinder head 4-6 and its drive via the outlet camshaft have been adopted.



1_41_09

Fuel high-pressure pump

On the 3.4-liter engines with direct fuel injection, the fuel high-pressure pump is fitted on the cylinder head of cylinder bank 1-3 and is driven by the outlet camshaft.

Positive crankcase ventilation

During combustion, every engine blows some of the combustion gases past the piston towards the crankcase – these gases are called blow-by gases. If these gases were not drawn off, the pressure in the crankcase would increase considerably. A vent connection is fitted in the crankcase for this reason. For environmental protection reasons, these gases are not released into the atmosphere but are sent back to the engine for combustion via the intake system.

Of course, these positive crankcase ventilation gases contain a proportion of engine oil and other combustion residues as well as a lot of fuel residues in some cases. If these gases get into the intake duct, they will contaminate the intake air and can then impair running smoothness and exhaust emissions and reduce knock resistance. It is obvious for these reasons why effective oil separation is important for the engine.

On the new flat engines this task is performed by the oil mist separator, which consists of a pre-separator and a fine separator.



1_42_09

Oil supply

The oil supply system in the new generation of engines has been thoroughly revised with the following objectives in mind:

- To ensure the supply of oil even during very high lateral and axial acceleration
- To reduce friction and drive losses

The main differences between the new oil supply system and that used on previous models are as follows:

- Additional oil extraction point per cylinder head
- Electrically actuated demand-controlled oil pump
- Watertight sheetmetal panel between crankcase and oil pan

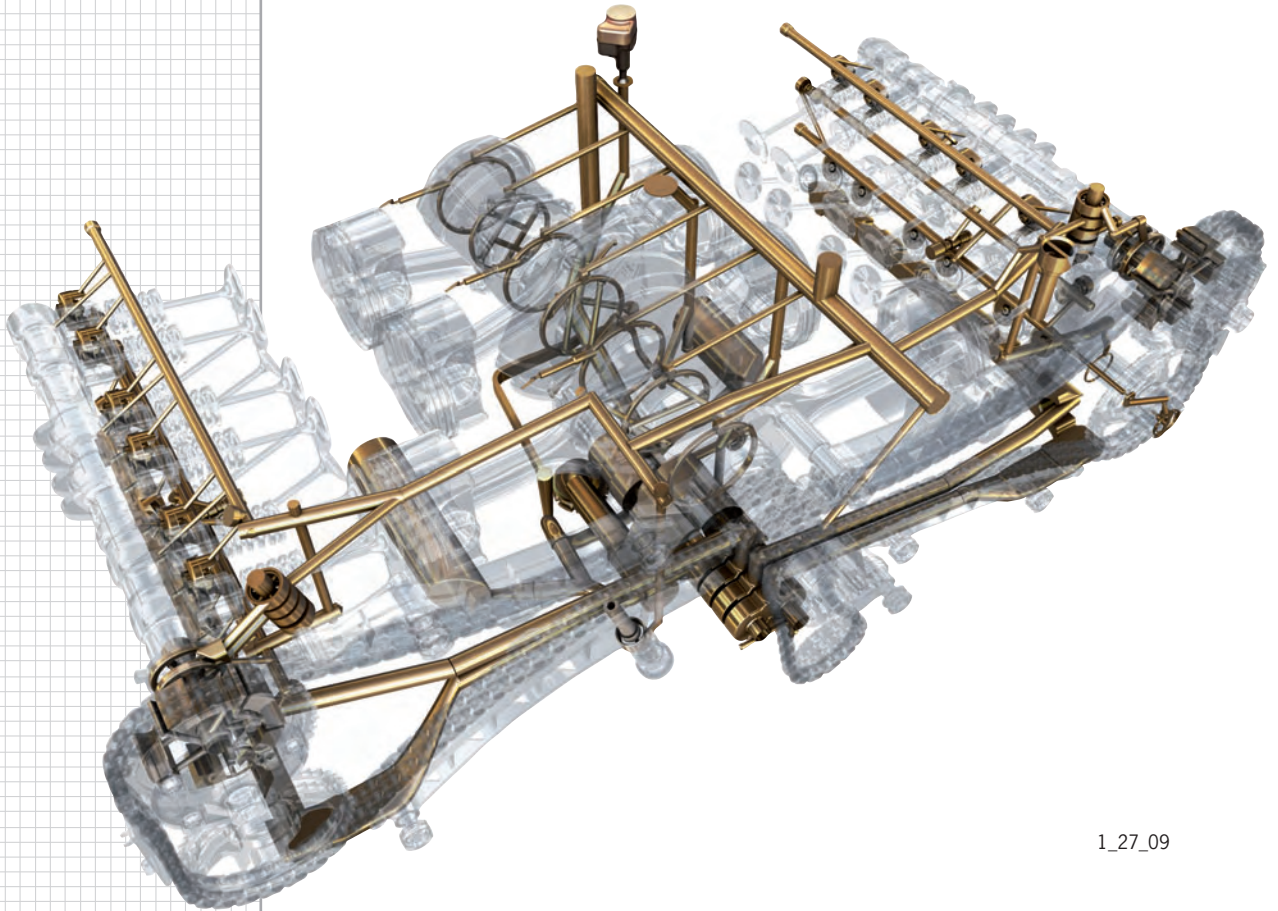

1_27_09

Compared to the previous models, the new 2.9 and 3.4-liter engines have not only one, but two extraction points in each cylinder head. In addition, the new Boxster and Cayman engines now have a total of 5 oil pumps instead of 3. These are located in the oil pan and are driven by a shared shaft. They include 4 extraction pumps for the cylinder heads (2 per cylinder head) and a new demand-controlled oil pressure pump.

Unlike in the 911 Carrera engines, the oil filter is accessible from beneath rather than from above. The oil pressure sensor is fitted on the top at the oil-filter console.

Demand-controlled oil pump

In order to reduce drive losses from auxiliary units and improve the efficiency of the engine, while at the same time reducing fuel consumption, the new Boxster and Cayman models are fitted with an electronic demand-controlled oil pump.

With this new oil pump, the delivery pressure and volume is controlled for the entire engine map. In other words: the required oil pressure and a defined oil volume is set for each engine operating state, e.g. different engine speed and load. The oil pump is integrated neatly in the oil pan area and is driven directly by the crankshaft via a chain.



1_43_09

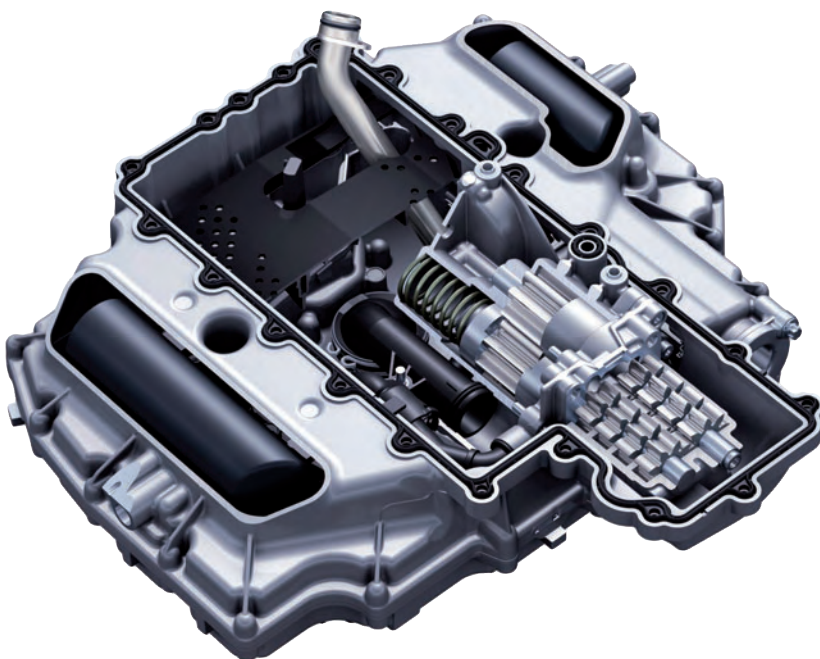

1_23_09

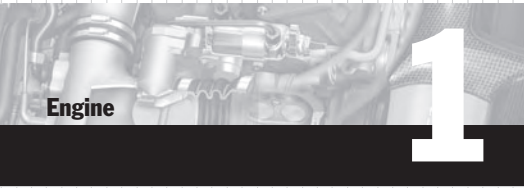

Engine

- 1 Drive wheel
- 2 Fixed gear wheel
- 3 Axially displaceable gear wheel
- 4 Control valve
- A de-energized
- B fully energized

Function

Depending on the input values for engine speed, engine load, engine oil temperature and the expected change in engine speed, a specific control valve (4) position is defined using a map in the DME control unit. The control valve position regulates the oil pressure for the spring piston on the gear wheel, which can move in axial direction. The oil pressure on the control piston is not regulated on the other side. The control valve is open fully in non-energized state and as a result, the oil pressure is the same on both sides, which means that the gear wheel will not move. In other words: the pressure difference between the spring piston and the control piston can be used to control every position. When the gear wheel moves, the teeth are still only partially engaged and as a result, power and friction as well as energy requirements are reduced.

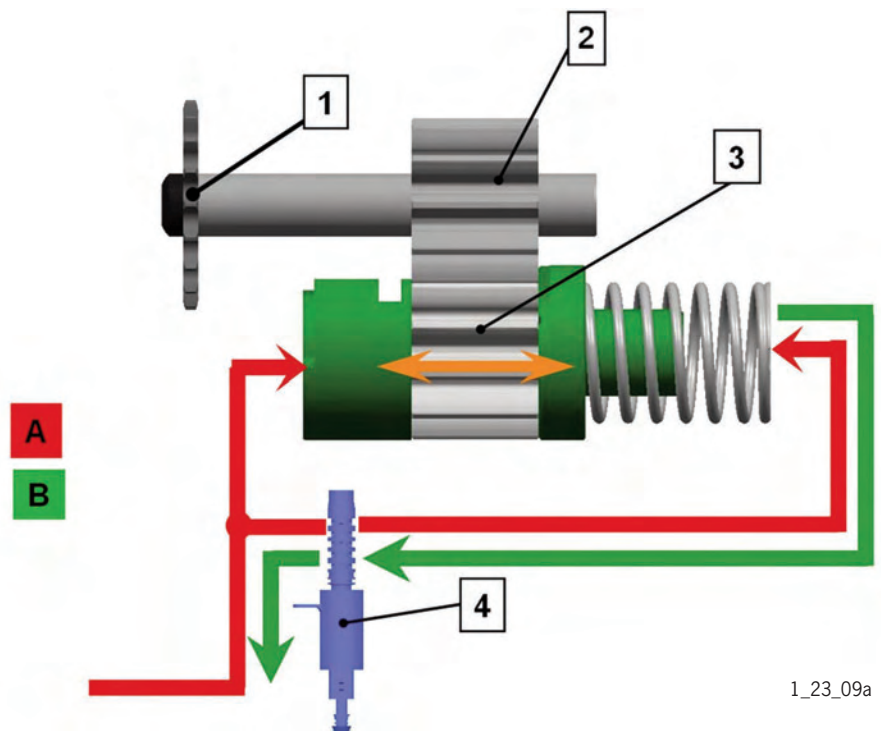

To extract oil from the two cylinder heads, the four additional oil pumps are integrated in the main oil pump housing so that the oil in the cylinder head in the new Boxster and Cayman engines is extracted at two points.



Cooling

The cooling concept is an enhancement based on the effective cylinder head cross-flow cooling used on previous models and was developed to selectively cool the hot spots in the cylinder head and crankcase. The design and position of the new coolant pump as well as the revamped internal engine cooling ducts in particular in the cylinder head are new.

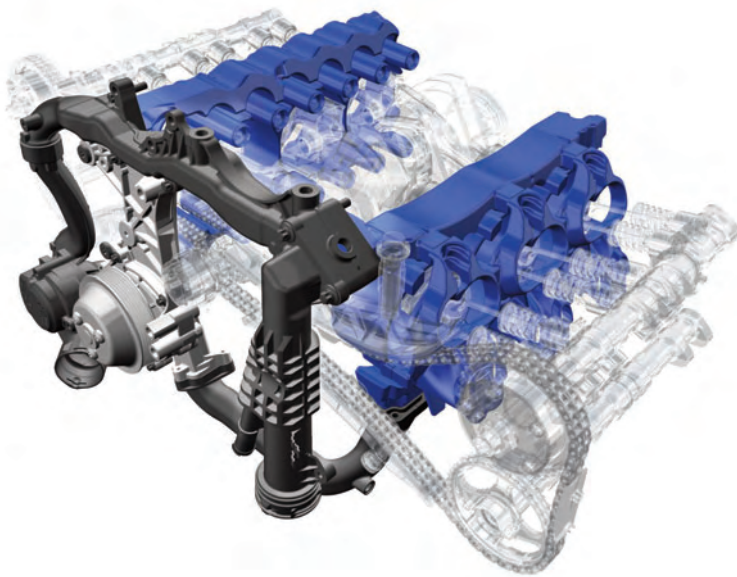

1_44_09

The new coolant pump is no longer located in the crankcase as an integral component, but instead it is attached to the outside of the crankcase on cylinder bank side 1-3 as a separate module driven by the belt. The advantage of this design is that it flexibly adapts the size of the water pump and reduces the maintenance costs if maintenance is required. To adapt to the improved engine performance and ensure adequate engine cooling, the maximum volume flow of the new pump has been increased by approx. 20%.

Boxster
Boxster S
Cayman
Cayman S

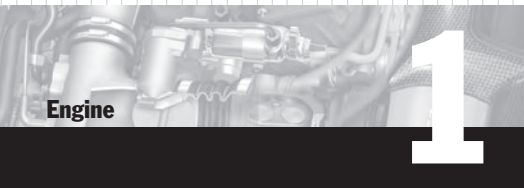

The greater engine power has resulted in a greater cooling requirement in the area of the cylinder head. The cooling ducts in the cylinder head have been revamped and the hottest spot on the positioning ring of the outlet valves has been additionally cooled to ensure cooling in this area, which is subject to substantial thermal loads.

This measure and the complete overhaul of the internal engine cooling have achieved steady and intense cooling in all operating states.



1_45_09





2 Fuel and ignition systems (DME)

The main focus here is on new developments and modifications compared to previous Boxster and Cayman models. More detailed basic information can be found in the Technical Service Information for the previous Boxster and Cayman models.

General information

All new Boxster and Cayman models, as with the new 911 Carrera, use a completely new generation of engines with significantly higher performance figures.

Both Cayman models have higher power output and torque values compared to the Boxster models. The result is better performance figures, which confirm the superior positioning of the Cayman models with regard to driving dynamics potential.

Boxster
Boxster S
Cayman
Cayman S

Fuel and ignition system

2

General information	27	2.9-liter engine with MPI	57
3.4-liter engine with DFI	28	DME control unit ME 7.8.2	58
DFI characteristics	32	Intake system	59
DME control unit EMS SDI 3.1	34	Fuel injectors EV14	59
Hot-film mass air flow sensor MAF 7	38	Exhaust system	60
Low-pressure fuel supply	39		
High-pressure fuel system	41		
Ignition system	49		
Air routing on intake side	51		
Exhaust system, emission control	53		

3.4-liter engine in the Boxster S, Cayman S with direct fuel injection (DFI)

The Boxster S and Cayman S models are also using totally redesigned 3.4-liter engines with direct fuel injection (DFI) from model year 2009. The power output of the new S models has increased to 310 bhp (228 kW) for the Boxster S and to 320 bhp (235 kW) for the Cayman S, while the displacement has stayed the same. This increase is mainly due to direct fuel injection (DFI). With direct fuel injection, the fuel is injected directly into the combustion chamber and mixture formation takes place almost completely in the combustion chamber. This offers numerous advantages compared to intake manifold injection. The main objective here is to achieve an air/fuel mixture adapted specifically to the respective operating and load states of the engine by means of injection and mixture formation. This provides the perfect solution for meeting the various demands relating to economy, power, vehicle handling and emissions.

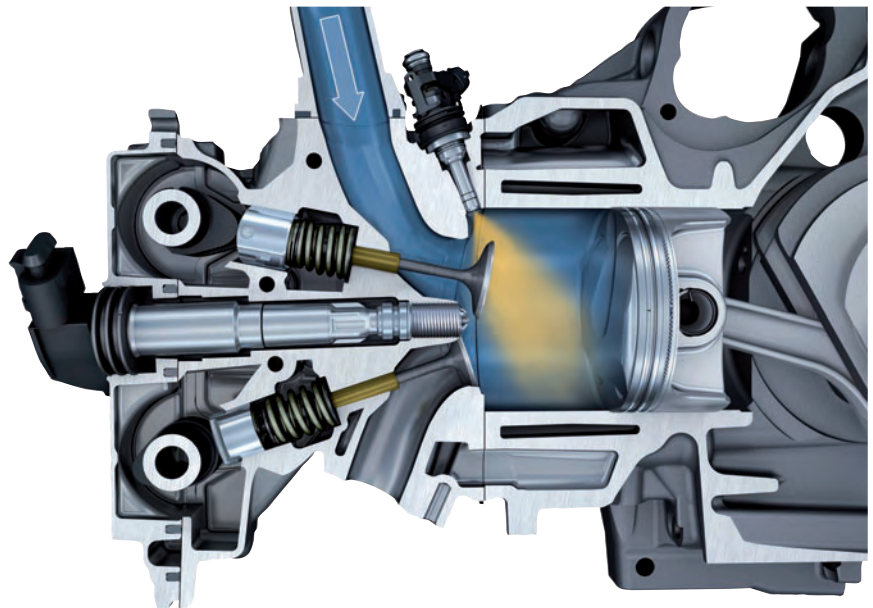

2_01_09

Development objectives for the new 3.4-liter flat engines with DFI:

- Increase in power and torque over the entire rpm range
- Better responsiveness
- Much lower fuel consumption values and CO₂ emissions combined with greater performance

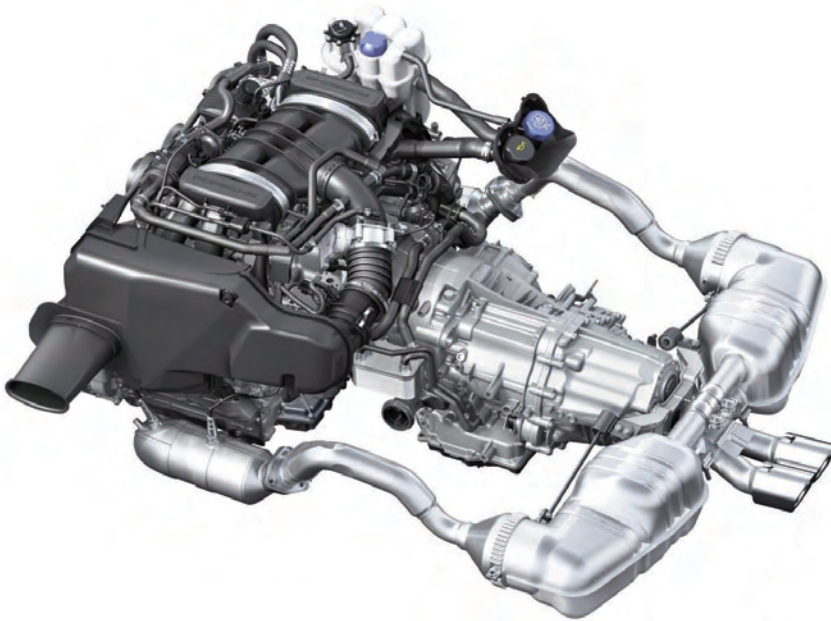

2_38_09

The illustration shows the 3.4-liter engine with DFI with intake system, exhaust system and Porsche Doppelkupplung (PDK).

These objectives have been achieved thanks to the following enhancements and technologies of the new 3.4-liter engines with DFI:

- Use of direct fuel injection (DFI)
- Engine control unit EMS SDI 3.1
- DFI-specific cylinder heads
- DFI-specific recessed pistons
- Higher compression ratio
- Electronic demand-controlled oil pump
- New intake system
- New exhaust system

The most important technical components of the direct fuel injection system are:

- The fuel low-pressure system
- The fuel high-pressure system
- The fuel high-pressure pump with flow control valve
- The fuel high-pressure line and the fuel distribution pipes to banks 1 and 2
- The fuel pressure sensor
- The fuel injectors (high-pressure fuel injectors)

The considerably higher performance figures of the new engines have been achieved mainly through the use of direct fuel injection (DFI), modification of the intake and exhaust systems and improvements within the engines. It was possible to increase the engine power and torque and reduce consumption and emissions without changing the displacement. Depending on the model, it was possible to reduce the fuel consumption and CO₂ emissions by up to 15% despite the enhanced performance. The new models also meet the stringent Euro 5 emissions limits. The country-specific data records of the new DME control unit EMS SDI 3.1 have been specially adapted to suit direct fuel injection and the modified engine specifications of the 3.4-liter engines.



Fuel and ignition system

3.4-liter engine with DFI in the Boxster S, Cayman S

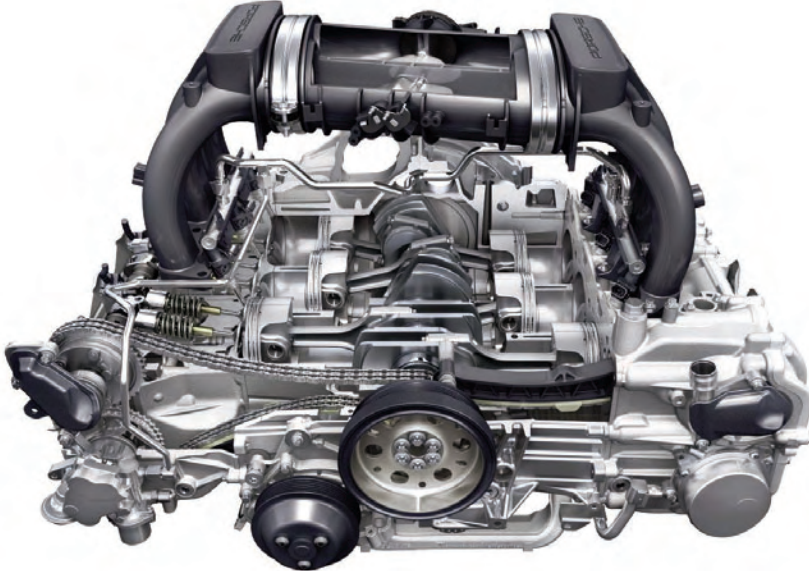

2_39_09

The idle speed of the new DFI engines on the S models is set to 680 +/- 40 rpm and the maximum engine speed is limited to 7,500 rpm. The power output and torque have been increased, while the displacement has stayed the same at 3.4 liters and the compression has been increased to 12.5 : 1.

Boxster S

Power output increased by 15 bhp to 310 bhp (228 kW) at 6,400 rpm, torque increased by 20 Nm to 360 Nm at 4,400 to 5,500 rpm.

Cayman S

Power output increased by 25 bhp to 320 bhp (235 kW) at 7,200 rpm, torque increased by 30 Nm to 370 Nm at 4,750 rpm.

Pistons in the 3.4-liter engine with DFI

The piston recess on the piston crown (shown in grey) is specifically designed to suit the characteristics of the 3.4-liter engine with DFI during late injection with high-pressure stratified charge ignition and during the catalytic converter heating phase. The higher compression ratio realised as a result of DFI serves to enhance performance and optimize fuel consumption.

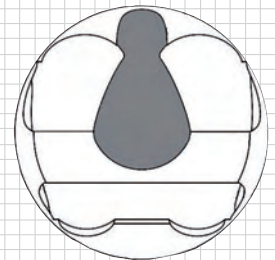

2_04_09

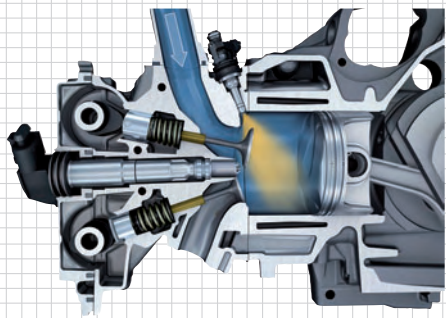

2_01_09



In the case of intake manifold injection, fuel is deposited on the intake manifold, cylinder walls and valves during the intake process and is therefore no longer available for combustion. This is particularly the case during the starting phase of the engine at low temperatures. The consequence of this is that heavy fuel enrichment is needed.

Characteristics of the 3.4-liter flat engine with direct fuel injection (DFI)

- Homogenous operation
- Better cylinder charging
- Reduced knock sensitivity
- Higher compression ratio
- High-pressure stratified charge ignition
- Multiple fuel injection

The direct fuel injection (DFI) used in the new flat engines is based on homogeneous direct injection. In this process, electromechanically controlled fuel injectors inject the fuel directly into the combustion chamber at a pressure of approx. 580 to 1740 psi (40 to 120 bar) and with millisecond accuracy as required by the respective driving state. The mixture of air and fuel is distributed as evenly as possible in the combustion chamber, thereby allowing optimal combustion.

The spray cone angle and injection-jet orientation of the injectors have been optimized to achieve optimum homogenization over the entire operating range. Within the injector, the fuel jet is twisted (rotated around the longitudinal axis). This rotation forms a conical cloud of fuel. The fine atomization produced in this way allows faster evaporation of the fuel.

The heat energy required to evaporate the fuel is absorbed from the combustion air, thereby cooling the air. This reduces the cylinder charge volume and additional air is drawn in through the open intake valve, which in turn improves cylinder charging.

Lowering the temperature reduces susceptibility to knocking and additionally allows the compression ratio to be increased. The higher compression ratio in turn increases the thermal efficiency of the engine. This reduces fuel consumption, particularly in the part-load range.



Starting phase of DFI engines with high-pressure stratified charge ignition

High-pressure stratified charge ignition is used in the DFI flat engines in order to optimize cold starting with regard to fuel consumption and emissions. In this process, fuel is injected once into the specially shaped piston recess just prior to the end of the compression stroke when the engine is being started. This forms a stratified charge around the spark plug to ensure that an ignitable mixture is formed.

This reduces both the amount of fuel required and the emissions during the starting phase compared to intake manifold injection.

Catalytic-converter heating phase of DFI engines with dual injection

Once the high-pressure stratified charge ignition starts the engine, the engine management system switches to the catalytic-converter heating phase. In this operating state, multiple injection helps to bring the catalytic converter up to the temperature required for optimal conversion of pollutants as quickly as possible.

To this end, the first injection of fuel takes place during the intake stroke and the second injection of fuel occurs into the piston recess when the intake valves are closed, just before the end of the compression stroke. The slightly lean air/fuel mixture (lambda value approx. 1.05) can then be ignited at a very late point, thus increasing the exhaust temperature. The resulting delayed combustion and the continued exothermic oxidation of unburnt fuel (excess oxygen) even after the exhaust valves have opened produce a considerably higher exhaust temperature directly with the use of dual injection to heat the catalytic converters.

The high exhaust temperature quickly heats the catalytic converters to the temperature for optimal conversion of pollutants. As a result, emissions during the warm-up phase are significantly reduced and the secondary air pumps are no longer required for all engines.

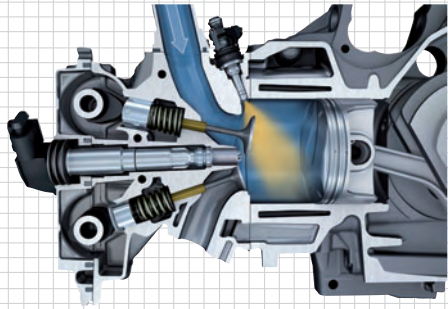

2_01_09



2_40_09



The DME control unit can be programmed with the data records for the various Boxster S and Cayman S models on a country-specific basis.

Upper load range of DFI engines

Engine operation at low rpm and high engine load leads to special requirements for the mixture-forming process within the engine. Here, dual injection takes place in the upper load range up to approx. 3,100 rpm. The amount of fuel required for combustion is distributed over two successive injection processes during the intake stroke. This multiple injection in synchronization with intake with open intake valves ensures better homogenization of the cylinder charge in the stated map ranges.

In the other engine map ranges and in the range near idle, the engines are operated with conventional single injection during the intake process.

DME control unit EMS SDI 3.1

The new 3.4-liter flat engines of the S models with DFI use the control unit EMS SDI 3.1 from Continental. The special demands relating to the use of direct fuel injection require significantly more functions and faster data processing. Compared to the ME 7.8.2 control unit of the new 2.9-liter engines with intake manifold injection, the control unit already installed in the new 911 Carrera models with DFI features even greater processing power with triple the clock speed and approx. 65% more memory capacity. It is particularly DFI injector control during multiple injection and the comprehensive data maps that require great computing power. A voltage of approx. 75 volts is required to open the DFI high-pressure fuel injectors. This requires 12-to-75 volt DC/DC converters, which are installed in the DME control unit. Some areas on the housings of these voltage converters become very hot. This heat is dissipated to the body via the bracket.



Fuel and ignition system

2

The DME control unit features the following key functions:

- Direct fuel injection (DFI) control
- Control of the DFI fuel injectors
- Control of the flow control valve for high-pressure control
- Control of the ignition coils with integral driver
- Control of the dynamic oil pressure control
- Communication with the hot-film mass air flow sensor MAF 7
- Communication with broadband oxygen sensors LSU 4.9 ahead of the catalytic converter (worldwide)
- Communication with step oxygen sensors LSF 4.2 behind the catalytic converter
- Communication with the optional Porsche Doppelkupplung (PDK)
- Communication with PSM
- Communication with the optional PTM
- Communication with the optional Sport Chrono or Sport Chrono Plus
- Control of the shift indicator

The DME control unit of the DFI engines receives input signals from the following sensors:

- Speed sender (engine speed and crankshaft reference mark)
- 2 hall senders (intake-camshaft position measurement)
- Hot-film mass air flow sensor MAF 7 (engine-load signal)
- Electronic throttle module (torque-demand measurement)
- Throttle angle (throttle valve position measurement)
- 2 knock sensors (for cylinder-selective knock control)
- 2 broadband oxygen sensors LSU 4.9 upstream of the catalytic converter (for stereo oxygen sensor closed-loop control)
- 2 step oxygen sensors LSF 4.2 downstream of the catalytic converter (for catalytic converter monitoring)
- Temperatures (cooling water, intake air, engine oil, ambient temperature)
- Vehicle speed
- Air conditioning level
- Fuel pressure (measurement of the fuel high pressure)
- Oil pressure
- Ambient pressure

CAN

The DME control unit receives information about the following via the CAN interface:

- Driving dynamics control
- Transmission control
- Engine immobilizer
- Instrument cluster
- Air conditioning control



Further information about the corresponding systems can be found in the following modules of this Technical Service Information (SIT):

- 1 Engine
- 3 Transmission
- 4 Chassis
- 9 Electrics

The DME control unit controls the following actuators:

- 6 ignition modules (individual ignition coils with integral driver)
- 6 fuel injectors (high-pressure fuel injectors)
- Control unit for fuel pump
(for demand control of the in-tank fuel pump, low-pressure side)
- Flow control valve (for flow control on the fuel high-pressure side)
- Throttle actuator control (adjustment by electronic throttle from idle speed to full load)
- 4 oxygen sensor heaters
- 2 camshaft position control actuators (adjustment of the intake camshafts)
- 2 valve-lift actuators (to change the valve lift of the intake camshafts)
- Tank vent valve
- Continuous engine-fan control
- Starter control
- Oil pressure control (demand oriented)
- Switching valve for tuning flap
- Switching valve for distribution pipe flap
- Control of the shift indicator
- OBD lamp (for monitoring the emission control system)

Other functions of the DME control unit

Control of VarioCam Plus

The new DFI flat engines retain the proven VarioCam Plus technology from the previous model. In addition to intake-camshaft adjustment from 0 to 40° crank angle, this system also allows valve-lift adjustment of the intake valves from 3.6 mm to 10.5 mm for the 3.4-liter DFI engine. In the case of the 2.9-liter MPI engine, the valve lift is adjusted from 3.6 mm to 10.0 mm. Besides the best possible running quality, favourable fuel consumption and low pollutant emissions, this above all ensures high power output and torque values in combination with the appropriate intake system.

Variable oil pump

The DME control unit is responsible for demand-controlled operation of the variable oil pump, while adjustment is performed hydraulically. The engine management system uses the input values for engine speed, temperature and torque. Based on this information, the engaged gear wheel width and thus the geometric displacement volume of the gear wheel set is changed through the axial movement of a gear wheel (moved hydraulically) and this in turn changes the delivery quantity and the oil pressure. The pump ensures that only the pumping work required for the relevant load range of the engine is demanded. This reduces the energy consumption of the oil pump to a minimum and also ensures demand-controlled lubrication.

Control of electric radiator fans

The DME control unit also activates the drivers for the electric radiator fans in order to achieve infinitely adjustable control.

Communication with the Porsche Doppelkupplung (PDK) control unit

The complex co-ordination between the engine and the optional Porsche Doppelkupplung (PDK) also requires a highly dynamic, powerful engine control unit. Only these parameters allow high performance and low fuel-consumption values and exhaust emissions to be ensured.

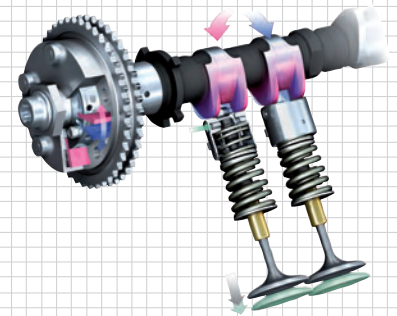

2_07_09



2_41_09



2_42_09



2_43_09

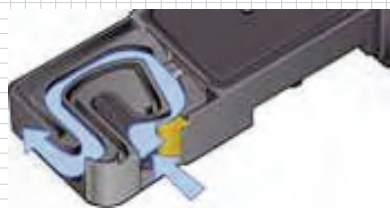

2_44_09



2_45_09

Hot-film mass air flow sensor MAF 7

All new Boxster and Cayman models from model year 2009 use the new hot-film mass air flow sensor MAF 7-RP (RP = Reduced Pressure Drop). This mass air flow sensor has a 5-pin connector with a trapezoidal shape and is welded to the measuring tube. Like its predecessor (MAF 5), it too generates an analogue voltage signal according to a thermal measuring principle. The intake air temperature is measured at the same time. There is a special bar for air routing in the measuring tube to the right of the MAF to optimize the air flow (see Figure 2_42_09).

The MAF 7 comprises the following main components:

- Micromechanical sensor element with return-flow detection
- Sensor electronics with signal processing and interface
- Intake air temperature sensor (NTC)

Advantages of the MAF 7:

- Low tolerances, better characteristic
- Less sensitive to water, particles and oil
- Compact design and minimal pressure drop
- Return-flow detection
- Flexible installation position
- Good robustness und dynamism
- Integrated temperature compensation

If the mass air flow sensor fails, the DME control unit uses a substitute mass air flow model that is stored in the engine control module for this eventuality.

Bypass duct

The flow characteristics of the bypass duct have been optimised compared to the previous MAF 5 model. The partial flow required to measure the mass air flow is drawn into the bypass duct behind a deflection edge (Figure 2_44_09). The design of the deflection edge causes a vacuum to be produced behind it. This vacuum draws the partial air flow required to measure the mass air flow into the bypass duct. The inert dirt particles are left behind by this fast motion and are returned to the intake air via an elimination bore (Figure 2_45_09). This means that the dirt particles cannot falsify the measurement result and damage the sensor element.

Fuel supply

The engine is designed to provide optimum performance and fuel consumption if unleaded unleaded fuel 93 octane ($\frac{R+M}{2}$). When fuel with 90 octane ($\frac{R+M}{2}$) is used, the engine's knock controller automatically adapts the ignition timing. The fuel tank's filling capacity is approx. 16.9 gal. (64 liters), including approx. 2.6 gal. (10 liters) reserve capacity.

Fuel low-pressure system in 3.4-liter DFI flat engines

- The low-pressure system delivers the fuel from the fuel tank to the high-pressure pump on the right cylinder head (bank 1)
- The new 3.4-liter DFI engines also feature a returnless fuel system (RF)
- The demand-control function of the fuel delivery rate reduces fuel heating in the tank (low-pressure system). A control unit adapts the voltage at the fuel pump.

Functional diagram of the low-pressure side in the fuel tank

Boxster S, Cayman S with DFI

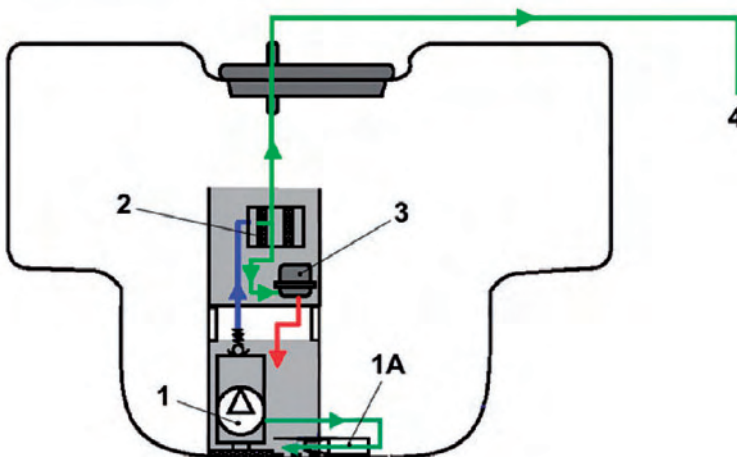

2_08_09



Observe the safety instructions in Group 2 of the Technical Manual when working on the fuel supply system.



The procedure for checking the fuel pressure, the delivery rate of the fuel pump and the holding pressure is described in the Technical Manual.

- 1 Fuel pump (for building up fuel pressure)
- 1A Sucking jet pump (for filling the pump chamber)
- 2 Fuel filter (lasts for the service life of the vehicle)
- 3 Fuel pressure regulator (approx. 5.0 bar)
- 4 Fuel low-pressure line (approx. 5.0 bar) to the high-pressure pump



In the case of the 2.9-liter engine with intake manifold injection (MPI), the fuel pressure regulator (3) maintains a fuel pressure of approx. 4 bar at the fuel injectors.

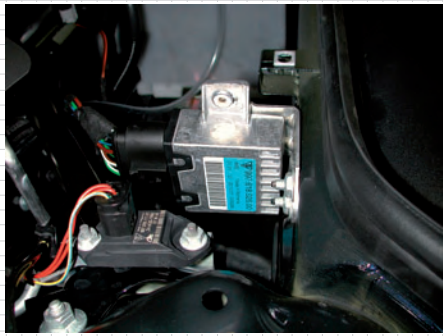

2_10_09

Fuel pressure on the low-pressure side

The fuel pressure on the low-pressure side is kept at a constant value of approx. 5.0 bar by the pressure regulator in the fuel tank (previous MPI systems: approx. 4 bar). Electronic pilot control of the delivery rate can cause the fuel pressure to deviate slightly for a brief period, e.g. during extreme load changes when the vehicle is being driven. To prevent the formation of vapor bubbles in the fuel supply system, the sustained pressure should not fall below 4.0 bar within 20 minutes of the engine being shut off.

Fuel pump control unit

In the case of the DFI engines, the fuel pump control unit controls the voltage at the electric fuel pump in order to adapt the delivery rate of the fuel pump to the engine fuel requirement. This is performed via the control unit installed on the right-hand side of the plenum panel. The control unit is activated by a PWM signal from the DME control unit. The linear control range of the PWM signal has a pulse/duty factor of approx. 60% - 90%. The voltage control varies the current draw of the pump in the range between approx. 6 and 14 amperes.

The following control criteria are stored in the DME control unit:

- The fuel pump runs for approx. 3 seconds when the ignition is switched on.
- When the engine is started and depending on the engine-start temperature, activation takes place for approx. 5 seconds at high voltage to achieve the maximum delivery rate.
- Afterwards, activation depends on the engine's fuel consumption. At idle speed, the fuel pump is activated at minimal voltage (>8 volts). Depending on fuel consumption, activation is continuously increased up to the maximum delivery rate of the electric fuel pump.

Fuel high-pressure system in DFI flat engines

The fuel high-pressure system generates the injection pressure of 580 to 1740 psi (40 to 120 bar). The fuel is distributed to the high-pressure injectors by the high-pressure pump via the high-pressure lines to the fuel rails of cylinder banks 1 and 2. The following pages describe the function of the components for the 3.4-liter flat engine with DFI.

The fuel high-pressure system comprises the following components:

The illustration depicts the high-pressure pump (HD). The flow control valve (MS), the temperature compensator and the pressure control valve are integrated into the high-pressure pump.

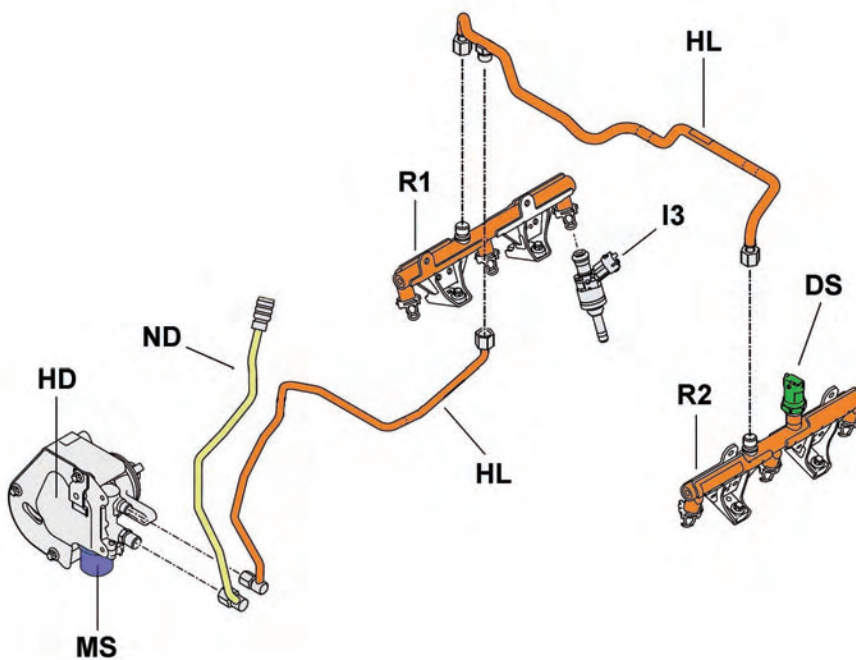

2_11A_09



Observe the instructions in the Technical Manual and perform a leak test when fastening all fuel lines to the fuel high-pressure system.

- ND Low-pressure line (approx. 5.0 bar from fuel tank)
- HD Fuel high-pressure pump (with flow control valve, pressure control valve and temperature compensator)
- MS Flow control valve (flow control by high-pressure control from 580 to 1740 psi (40 to 120 bar))
- DS Fuel pressure sensor (high pressure)
- HL High-pressure feed and connecting line to the rails
- R1 Fuel rail for cylinder bank 1
- R2 Fuel rail for cylinder bank 2
- I3 Fuel injector for cylinder 3

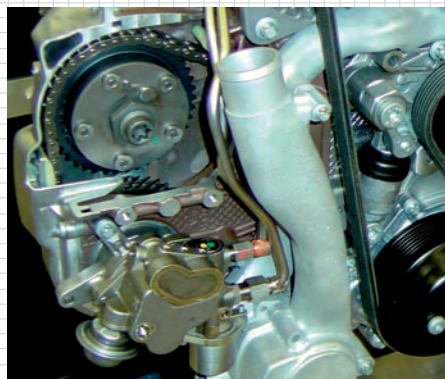

2_12_09

- A Drive of the three-piston high-pressure pump via the exhaust camshaft
- ND Low-pressure line
- MS Flow control valve
- HL High-pressure line
- TK Temperature compensator

Control and temperature compensation

Depending on the amount of fuel required and the calculated fuel temperature, the DME control unit, together with the flow control valve, regulates the amount of fuel on the high-pressure side upstream of the high-pressure injectors. In the DFI flat engines, the fuel temperature on the low-pressure side (upstream of the high-pressure pump) is calculated by a temperature model in the DME control unit. The following information is included in the model: outside temperature, temperature of the flow control valve, operating duration, load point, tank filling level, idle period prior to vehicle start.

Fuel high-pressure pump

The fuel high-pressure pump provides the amount of fuel required for injection and the fuel pressure from 580 to 1740 psi (40 to 120 bar). The axial-piston pump is driven by the exhaust camshaft of cylinder bank 1. The high-pressure pump is a three-piston pump with a maximum delivery rate of approx. 47.5 gph (180 liters/h) at 120 bar. It builds up pressure and ensures flow control. The following components are integrated into the high-pressure pump: flow control valve with pressure-reducing function for the fuel high-pressure side, pressure control valve, bypass valve, a temperature compensator on the oil side and a fuel strainer on the intake side with a mesh size of approx. 50 microns.

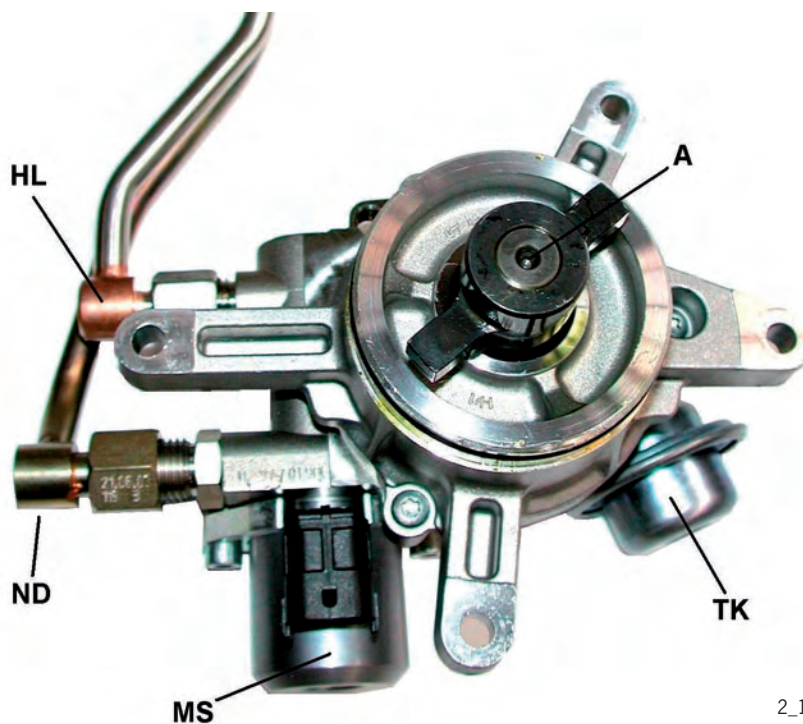

2_13_09

Flow control valve for fuel high pressure

The flow control valve is an electric control valve and is located on the intake side (low-pressure side) of the high-pressure pump. The DME control unit activates the flow control valve using a current of 0 to approx. 2 amperes, resulting in flow control from 580 to 1740 psi (40 to 120 bar) by the high-pressure control system. When the engine is switched off, the fuel high pressure is reduced by an integrated pressure-reducing valve. The (monitoring) measurement of the fuel pressure is performed by the fuel pressure sensor (approx. 580 to 1740 psi/40 to 120 bar).

If the control valve fails, the DME control unit goes into emergency mode, whereby the engine can still operate in a limited manner with low pressure (approx. 5.0 bar). In this case, the bypass valve in the pump opens and provides a direct route from the low-pressure side to the high-pressure side. The Check Engine light is activated.

The bypass valve is also activated when the empty fuel rail is filled on new engines or following repairs in order to reduce starting times.

Pressure control valve

The pressure control valve is integrated into the fuel high-pressure pump. This safety valve opens a connection to the fuel low-pressure system if the fuel pressure in the high-pressure system exceeds approx. 2030 psi (140 bar).

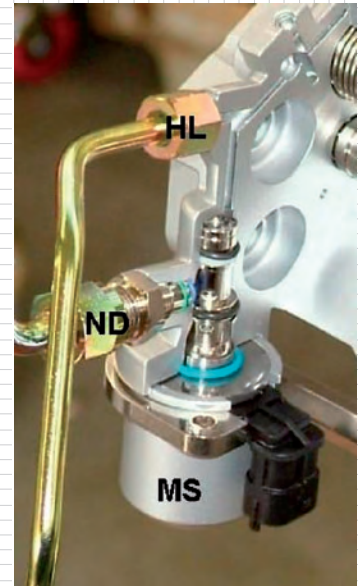

2_14_09

- ND Low-pressure line (approx. 5.0 bar from fuel tank)
- MS Flow control valve (for fuel high-pressure control)
- HL High-pressure line to the fuel rails

- ND Low-pressure side (input)
- HR To the high-pressure rails
- DR Pressure control (connection to the high-pressure side)
- MSV Flow control valve
- ÜB Pressure relief and bypass valve
- EV Intake valve
- AV Exhaust valve
- PK Pump piston
- MF Metal bellows

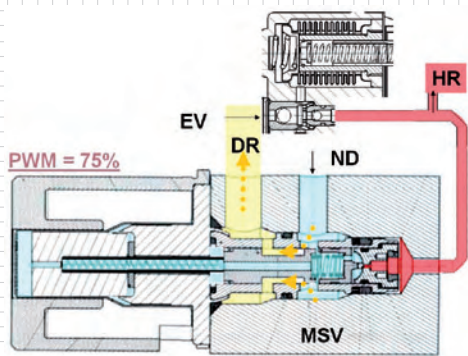

2_16_09



After replacement of the high-pressure pump (with flow control valve), the adaptation values must be reset and an adaptation test drive carried out in order to guarantee control stability. Observe the corresponding information according to the Technical Manual.

Fuel high-pressure control

The fuel is sucked in from the low-pressure side (5.0 bar) by the pump pistons via the flow control valve and the intake valves. The pistons pump the fuel into the high-pressure system via the exhaust valves. The pressure relief and bypass valve has two functions. It protects the system against excessively high pressure and relieves the pressure from the high-pressure side when the engine is switched off.

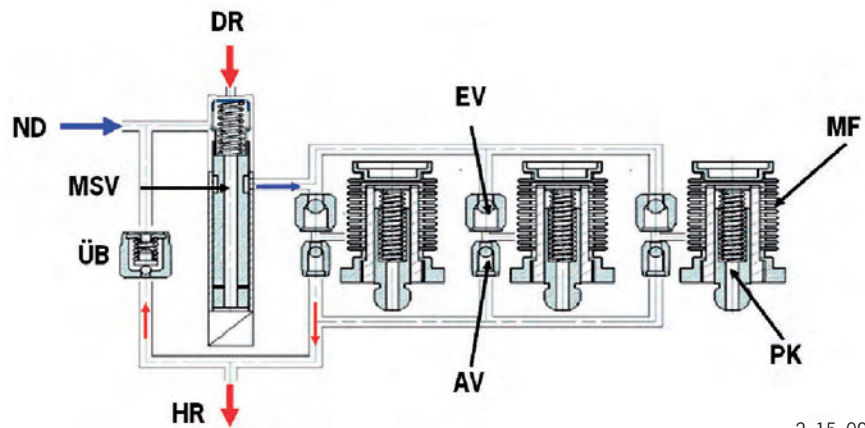

2_15_09

The flow control valve (see picture 2_16_09) has specific flow tolerances between the valves due to its design. For this reason, the characteristic while driving is adjusted to the respective valve by the high-pressure adaptation ranges 1 to 5. The DME control unit activates the flow control valve using a current of 0 to approx. 2 amperes. This maintains the fuel pressure at between 580 to 1740 psi (40 to 120 bar) when the engine is running.



The fuel high-pressure system normally operates in flow control mode.

Pressure control is activated only when the fuel flow rates are very low near idle speed:

- Engine at idle speed
- High oil and coolant temperature
- High fuel share from tank ventilation
- Low engine load (AC off, low vehicle electrical system load)

The graph shows the characteristic spread which is balanced out by high-pressure adaptations 1 to 5. The respective adaptation range is 0 +/- 25%.

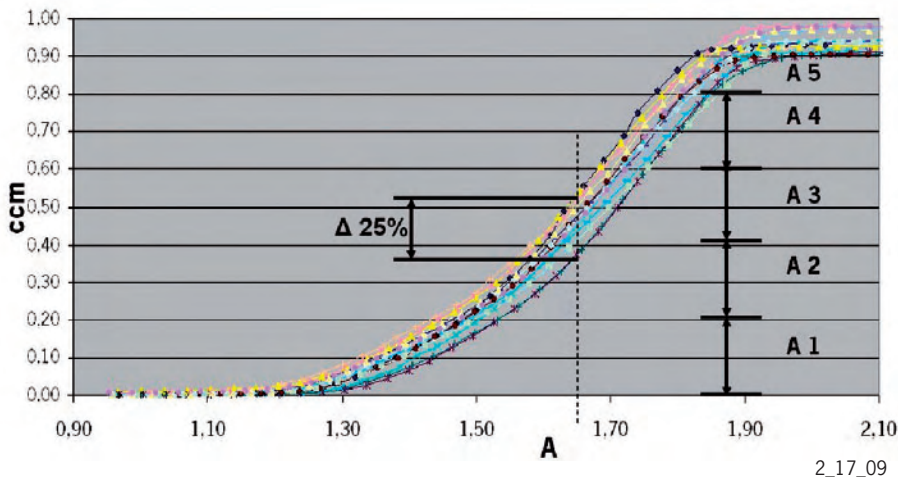

- A1 Adaptation range 1
- A2 Adaptation range 2
- A3 Adaptation range 3
- A4 Adaptation range 4
- A5 Adaptation range 5
- ccm Flow quantity (ccm/revolution)
- A Activation current (amperes)

High-pressure lines

The fuel is pumped by the high-pressure pump to the fuel rails for cylinder banks 1 and 2 via the high-pressure feed and connecting line.

High-pressure rail for bank 1 and bank 2

Two high-pressure rails are used in the DFI flat engines (depending on the type). The fuel injectors for banks 1 and 2 are fastened to the cylinder head over the high-pressure rails, which are located under the intake system. The high-pressure rails provide the same fuel pressure to all fuel injectors. The volume of the high-pressure rails is adapted according to the amount of fuel the engine needs. It is approx. 100 cubic centimeters for the 987 DFI engines.



Observe the instructions in the Technical Manual and perform a leak test when fastening all fuel lines to the fuel high-pressure system.

- R2 Fuel rail for cylinder bank 2
- DS Fuel pressure sensor (high pressure)
- I Fuel injector

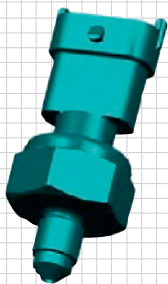

2_19_09

The rail volume is determined by the permissible pressure variation behavior and a short starting time. The volume and the chokes in the high-pressure system dampen pressure-induced vibrations, but they delay attainment of the release pressure for injection when the engine is started.

Illustration of fuel rail for bank 2

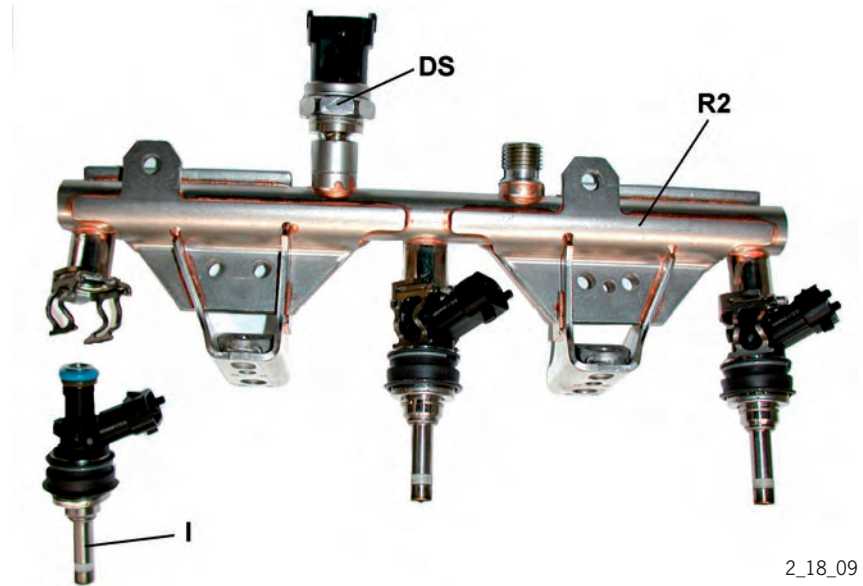

2_18_09

Fuel pressure sensor

The fuel pressure sensor is fitted on the high-pressure rail for bank 2 and informs the DME control unit about the current pressure in the fuel high-pressure system. The DME control unit evaluates this input signal and regulates the fuel quantity on the high-pressure side via the flow control valve.

Fuel injectors/DFI high-pressure injectors

The electromagnetically operated fuel injectors are on the intake side of the cylinder heads. They are activated by the DME control unit in accordance with the firing order. Following activation, they inject fuel directly into the combustion chamber at a pressure of 580 to 1740 psi (40 to 120 bar). The fuel is given a spin even before it leaves the tip of the fuel injector (see picture 2_104_07) and is injected in a finely atomized, conical jet. The connection to the rails is via an O-ring connection.

According to the engine operating state (start, idling, partial load, full load), the quantity of fuel injected is distributed over one or two injections in the rpm range below approx. 3,100 rpm, depending on the operating point. This supports mixture formation and thus the engine operating behavior. When the engine is started from a cold state, some of the fuel is injected only immediately prior to ignition. This reduces the fuel quantity required for starting. Injection is released once a defined, temperature-dependent pressure has been reached (approx. 35 to 100 bar).

Fuel injectors

The fuel injectors of the 3.4-liter engines are designed specifically to suit the engine's fuel requirement.

- Injection quantity at 580 psi (40 bar) fuel pressure and 0.6 ms injection time: approx. 7.35 mg/stroke
- Injection quantity at 1740 psi (120 bar) fuel pressure and 5.2 ms injection time: approx. 77 mg/stroke
- Injector-needle stroke: approx 50 microns
- The characteristic drop diameter is approx. 30 microns
- Spray-cone angle: approx. 69°
- Bend angle: approx. 15°

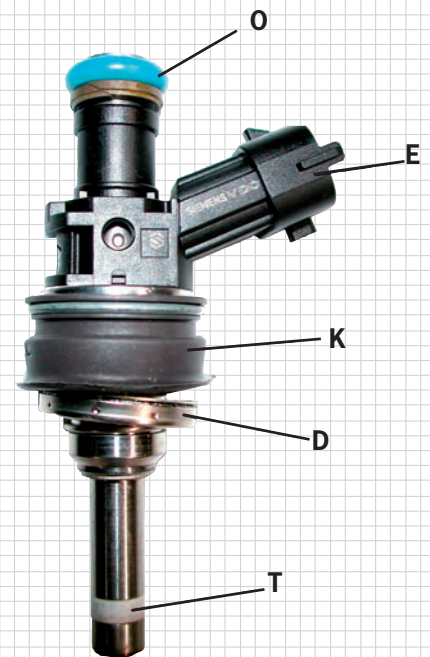

2_20_09

- O O-ring on hydraulic connection
- E Electrical connection
- K Corrosion protection (external)
- D Spacer ring
- T Teflon sealing ring (to combustion)

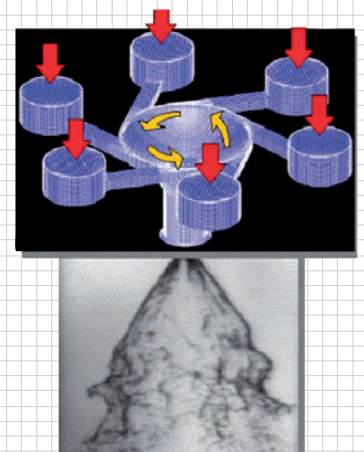

2_104_07

The illustration shows a typical DFI fuel injector

- S The spray-cone angle is the spray angle of the fuel jet and is approx. 69°
- B Bend angle (deviation of the injection jet from the axis of the fuel injector; this is approx. 15°)



A defective injector is detected by the misfire detection system and is not activated again.

In addition to the amount of fuel injected, the injection time and the drop size, the shape and alignment of the fuel jet are also important.

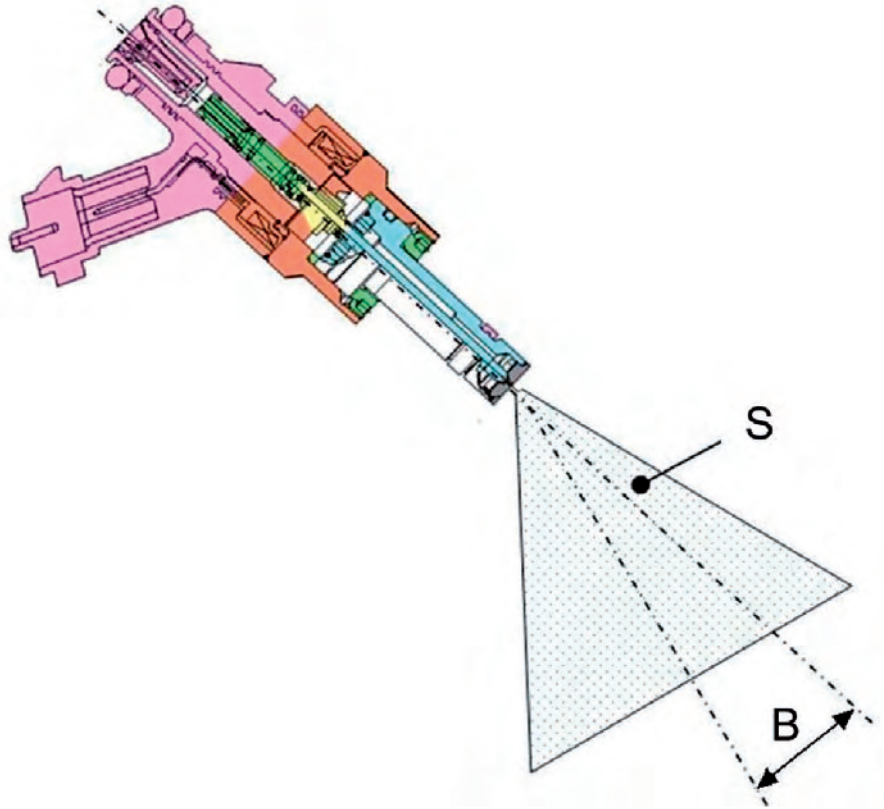

2_91_07

Ignition system

General information

The functional principle of the ignition system for the new 2.9-liter and 3.4-liter flat engines essentially corresponds to that of the Cayenne V8 DFI engines. The ignition system map in the DME control unit has been designed to meet DFI-specific requirements.

Knock sensors

One knock sensor each is fastened to the left and right crankcase sides. These sensors detect knocking combustion in the corresponding cylinders. To prevent knocking, the cylinder-selective knock control system monitors the electronic ignition-timing control system. Based on the signals from the knock sensors, the DME control unit adjusts the ignition timing angle for the knocking cylinder until the knocking stops. If a knock sensor fails, the ignition timing angles of all cylinders are retarded under load. In other words, a safety timing angle in the "retarded" direction is set. This considerably reduces the engine power and increases fuel consumption.

Ignition coils

All new flat engines feature static high-voltage ignition distribution with active individual ignition coils directly on the spark plugs. The new individual ignition coils feature an integrated output driver (active ignition module) that is activated individually for each cylinder in the firing order 1-6-2-4-3-5 by the DME control unit. Furthermore, the diagnostic function is also integrated into the ignition module. If an ignition coil fails, fuel injection for the affected cylinder is deactivated.

This system offers the following advantages:

- High level of ignition reliability
- Minimum electromagnetic interference with other electronic components
- No requirement for ignition cables and ignition distributor



Observe the safety instructions in Group 2 of the Technical Manual when working on the ignition system.



2_22_09



The ignition coil does not have to be tilted during removal because the ignition coil unit extends into the spark-plug recess.

- A Fastening eyelet
- B Plug connection
- C Spark-plug recess seal
- D High-voltage plug to the spark plug
- 1 Output final stage
- 2 Heat sink for output final stage
- 3 Electronics printed circuit board (with integrated diagnostic function and current limitation)
- 4 Magnetic core
- 5 Secondary winding
- 6 Primary winding
- 7 Electrical resistor



Refer to the market-specific maintenance schedule for the change interval of the surface-gap spark plugs.

- 1 Surface arc gap
- 2 Ground electrode
- 3 Center electrode
- 4 Insulator

Ignition coil with integral driver

All parts in this newly developed component are installed as a complete unit in a special rod ignition module housing. This is connected electrically and mechanically to the spark plug in the spark-plug recess via the short high-voltage plug. The component is also secured mechanically using bolts. The ignition coil is sealed at the four-pin plug and in the spark-plug recess to protect it from spray water. Compared to the illustrated Cayenne V8 ignition coil, the output final stage of the new sports car rod ignition module is located directly on the printed circuit board. There is no longer a separate heat dissipator (2). The cooling concept has been integrated into the printed circuit board.

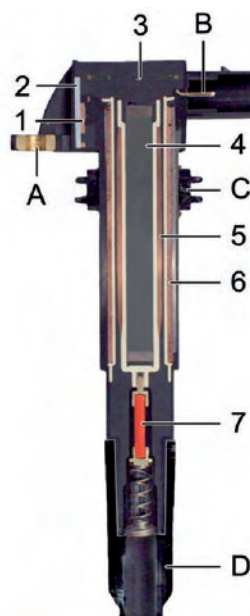

2_23_09

Surface-gap spark plugs

The four ground electrodes are arranged around the ceramic insulator in the surface-gap spark plugs. The sparks (1) cross the surface of the insulator (4) and arc across a small gas gap to the ground electrode (2), which improves the ignition properties. The main advantage of the surface-gap spark plug is the self-cleaning effect of the insulator foot tip, since any shunts that occur between the center electrode and the ground electrode through the surface gaps, in particular during a cold start, are eliminated.

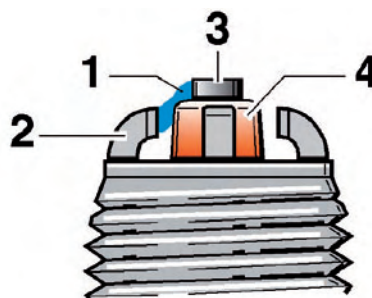

2_05_02

Intake air side, air routing

Air cleaner

All new Boxster and Cayman models are fitted with the same air cleaner as their previous models.

On the Boxster models only, the size and position of the opening to the Helmholtz resonator (H) have been modified at the air cleaner output in the intake area for the intake system. This improves the intake noise, in particular on the "open" Boxster models with minimal intrinsic insulation from the roof construction or when driving with the top down.

Intake system of the 3.4-liter DFI engine

All engines on the new Boxster und Cayman models are fitted with a new intake system. As in the previous generation of engines, it is a resonance intake system made of plastic with resonance tube and distribution pipe between the right and left intake manifolds. The functional elements with switchable tuning and distribution pipe flaps have also been retained.



2_47_09

The design of the centre part between the right and left intake manifolds is new. What were originally two individual components (resonance tube and distribution pipe) have been combined in one housing. The geometry of the tuning and distribution pipe flaps has been changed to a half oval to match the shape of the now oval centre part.



2_46_09



Refer to the market-specific maintenance schedule for the change interval of the air-cleaner element.

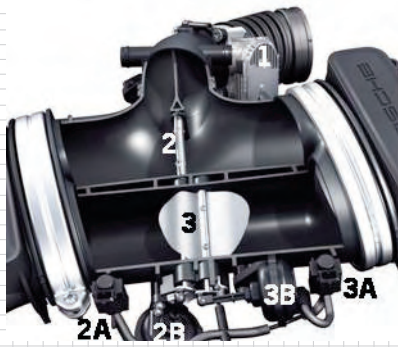

2_48_09

- 1 Electronic accelerator
- 2 Flap of twin-flow distribution pipe
- 2A Switching valve
- 2B Diaphragm cell
- 3 Tuning flap
- 3A Switching valve
- 3B Diaphragm cell



2_49_09

Tuning flap

As on the previous models, the switchable tuning flap allows the air oscillations in the intake system to be adapted to the respective engine speed. This ensures high torques even at low engine speeds, a more uniform torque curve and high maximum power. The tuning flap is actuated by a vacuum-controlled diaphragm cell (MD). It is activated as controlled by the map by means of an electropneumatic switching valve installed on the resonance tube. In the case of the 3.4-liter DFI engine, the tuning flap is closed by means of vacuum at idle speed and opens by means of ventilation above 5,300 rpm.

Twin-flow distribution pipe

As on the previous models, the twin-flow distribution pipe with switching flap improves the torque in the lower rpm range. A partition panel running longitudinally in the intake tube between the throttle valve and distribution pipe and the switchable distribution pipe flap allows the right and left cylinder banks to be connected and disconnected. The distribution pipe flap is closed in the lower rev range, which means that the 6-cylinder engine behaves like two 3-cylinder engines running in parallel in this rpm range. The distribution pipe flap is actuated by a vacuum-controlled diaphragm cell. It is activated as controlled by the map by means of an electropneumatic switching valve installed on the resonance tube. In the case of the 3.4-liter DFI engine, the distribution pipe flap is closed by means of vacuum at idle speed and opens by means of ventilation above 3,800 rpm.

Intake manifold

The geometric dimensions of the individual pipes of the intake manifolds of the right and left cylinder banks have been adapted to the engine characteristics of the 3.4-liter engine. The resonance chamber in the upper part of the intake manifolds that is integrated into the component has also been redesigned. This resonance chamber attenuates disturbing resonance sounds in the upper rev range and makes an important contribution to the harmonious and powerful sound at full throttle. The additional acoustic chambers are integrated into the lateral intake manifolds and are connected to them via a perforated partition with numerous small openings.

Exhaust system, emission control

General information

The exhaust systems on all new Boxster and Cayman models have been redesigned to achieve maximum performance with minimum emissions.

Design of the exhaust system

The new Boxster and Cayman models are fitted with a completely redesigned exhaust gas system compared to the previous models. In particular the manifolds with enlarged tube cross sections, the catalytic-converter concept, the structure of the main mufflers and the tailpipes are new. All Boxster and Cayman models are equipped with the same exhaust system with two sound-optimized country versions (RoW/USA and PAP). These measures help to realise better performance figures and compliance with the Euro 5 emissions standard for Europe. In addition, the new catalytic-converter concept has reduced the weight of the overall exhaust system by approx. 2 kg (approx. 4.5 lbs) and the relocation of the main catalytic converters has lowered and centred the vehicle's centre of gravity. Tailpipes with different designs are used for the different models.

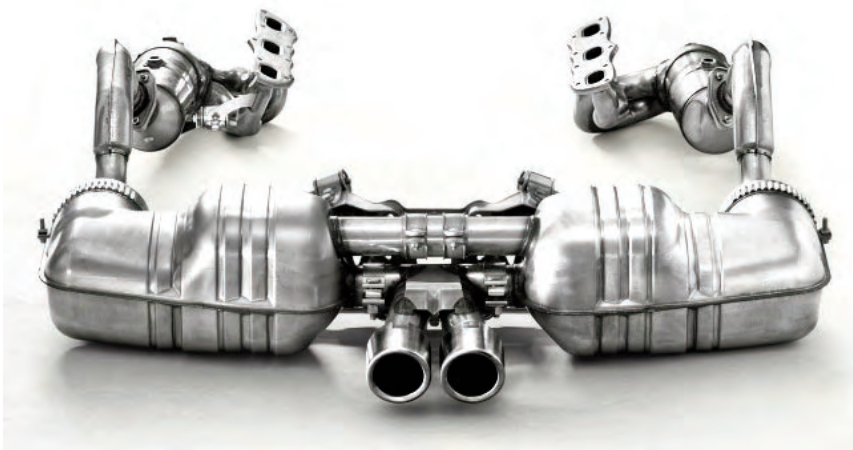

2_50_09

The illustration shows the exhaust system of a 3.4-liter engine with twin tailpipes. The exhaust gases flow from the exhaust manifold to the oxygen sensor LSU, through the first catalytic converter to the oxygen sensor LSF and then through the second catalytic converter to the main silencer. The two connecting pipes between the main silencers on the left and right mix the exhaust gases from cylinder banks 1 and 2 before they escape from the tailpipes.

- 1 Exhaust manifold
- 2 Oxygen sensor LSU 4.9
- 3 First catalytic converter
- 4 Oxygen sensor LSF
- 5 Second catalytic converter



2_52_09

Exhaust manifolds and catalytic converters

The redesigned manifolds with integrated main catalytic converters and nearly equal pipe lengths largely correspond to those of the new 911 Carrera models. They permit efficient conversion of pollutants and a balanced gas cycle between the cylinders.

The catalytic-converter concept has been modified compared to the previous Boxster and Cayman models. Instead of the main catalytic converters in the rear silencers and the primary catalytic converters in the manifolds, the new Boxster and Cayman models feature one larger main catalytic converter with two monoliths integrated into the manifold per cylinder bank. The larger diameter of the main catalytic converters compared to the pre-catalytic converters permits a lower exhaust backpressure for high performance figures. The substrate of the converters consists of ceramic material.



2_51_09

Rear muffler

The removal of the main catalytic converters from the rear silencers has enabled their internal structure to be completely redesigned. This permitted a new sound setup resulting in a fuller, round and more harmonious tone. A further advantage of this new setup is an improvement in the interior acoustics of the Cayman models.



Tailpipes on the S models

As on the previous models, the S models with 3.4-liter displacement are equipped with a twin tailpipe in stainless steel with a brushed finish. Identical twin tailpipes with a larger pipe cross-section and a new design are now used on the new Boxster S and Cayman S. The flow concept of the twin tailpipes is new. While on the previous models the twin-branch tailpipe is supplied from one central pipe, on the new S models the entire tailpipe is designed as a twin pipe system with two separate pipe connections.



Twin tailpipe on the Boxster S

2_53_09



Twin tailpipe on the Cayman S

2_54_09

Emission control

All new Boxster and Cayman models comply with all emissions limits currently applicable in the markets such as EURO 5 and LEV2/ULEV for USA. A reduced EURO 4 data record is used for countries with EURO 2 limits.

The new engine generations on all new Boxster and Cayman models satisfy the prerequisite for compliance with the new Euro 5 emissions standard applicable for Europe from 1.9.2009 (in place of Euro 4) primarily through the use of the electronically demand-controlled oil pump, reduction of the friction and power losses, a new catalytic converter coating and enhanced fine tuning of injection and ignition. The 3.4-liter engines with direct fuel injection (DFI) achieve the new limits without any secondary-air injection. The use of direct fuel injection (DFI) in the 3.4-liter engines permits the implementation of the thermodynamic injection and ignition strategy in the warm-up phase. The exhaust gas and ultimately the catalytic converter are heated up very rapidly even without using secondary-air injection by means of a lean mixture in combination with multiple injection and late injection angles. Combined with the position of the catalytic converters close to the engine, compared to the previous models it was even possible to shorten the warm-up phase for reaching the temperature required for the catalytic converters to effectively convert any pollutants. Overall, these measures bring about a reduction in the exhaust emissions and compliance with the stringent Euro 5 emissions standard in EU countries

2.9-liter engine with intake manifold injection ME 7.8.2 in the Boxster and Cayman

The illustration shows the 2.9-liter engine with intake manifold injection MPI with intake system, exhaust system and manual transmission.



2_55_09

Only the differences between the 2.9-liter engine with intake manifold injection and the 3.4-liter DFI engine are described below.

At a compression ratio of 11.5 : 1, the increase in power output of the completely new flat engine is due to the increase in displacement from 2.7 liters to 2.9 liters.

2.9-liter Boxster:

Power output increased by 10 bhp to 255 bhp (188 kW) at 6,400 rpm, torque increased by 17 Nm to 290 Nm at 4,400 to 6000 rpm.

2.9-liter Cayman:

Power output increased by 20 bhp to 265 bhp (195 kW) at 7,200 rpm, torque increased by 27 Nm to 300 Nm at 4,400 to 6000 rpm.

The idle speed is set to 680 +/- 40 rpm and the maximum engine speed is limited to 7,500 rpm.



2_62_09



The DME control unit can be programmed with the data records for the various Boxster and Cayman models on a country-specific basis.

DME control unit ME 7.8.2

The 2.9-litre engines with intake manifold injection are fitted with the new DME control unit ME 7.8.2 from Bosch. This control unit is an enhancement of the ME 7.8.1 control unit from the 997 Turbo. The new control unit with a clock speed of 40 MHz has been designed with greater processing power and increased memory capacity for the following additional functions of the new 2.9-liter engines:

- Hot-film mass air flow sensor MAF-7
- Broadband oxygen sensors LSU 4.9 ahead of the catalytic converter (worldwide)
- Step oxygen sensors LSF 4.2 behind the catalytic converter
- Fuel injector EV14
- Ignition coils with integral driver
- Control of the dynamic oil pressure control
- Communication with the optional Porsche Doppelkupplung (PDK)



Intake system of the 2.9-liter engine with intake manifold injection

The geometric dimensions of the individual pipes of the intake manifolds of the right and left cylinder banks have been adapted to the engine characteristics of the 2.9-liter engine. The resonance chamber in the upper part of the intake manifolds has also been redesigned. This new feature for the basic engines attenuates disturbing resonance sounds in the upper rev range and makes an important contribution to the harmonious, powerful sound at full throttle. In the case of the 2.9-liter engines with intake manifold injection, the openings for the fuel injectors are located in the flange area of the individual intake ports.

Tuning flap

The tuning flap is closed by means of vacuum at idle speed and opens by means of ventilation above 5,500 rpm.

Distribution pipe flap

The distribution pipe flap is closed by means of vacuum at idle speed and opens by means of ventilation above 3,800 rpm.

Fuel injectors EV14

New fuel injectors of the type EV14 from Bosch are installed in the new 2.9-liter engines with intake manifold injection. These fuel injectors have eight very fine discharge holes at the valve tip. Micro-electroplating allowed the spray pattern to be improved and the tolerances to be reduced. The fuel pressure of the engines with intake manifold injection is still approx. 4 bar.



2_56_09



2_57_09



2_58_09



2_59_09



Tailpipe on the Boxster

2_60_09



Tailpipe on the Cayman

2_61_09

Exhaust system for 2.9-liter engine

The exhaust system on the new Boxster and Cayman models is identical with the S models except for the tailpipe.

Emission control

The new 2.9-liter basic models of the Boxster and the Cayman with 2.9-liter engine and intake manifold injection continue to use secondary-air injection. The engines comply with all emissions limits currently applicable in the markets such as Euro 5 and LEV2/ULEV for USA. A reduced EURO 4 data record is used for countries with EURO 2 limits.

Tailpipe

The basic models with 2.9-liter displacement are equipped with an individual tailpipe in stainless steel with a brushed finish. The outer contour has been enlarged and the design modified compared to the previous models.





3 Porsche Doppelkupplung (PDK)

The new, optionally available Porsche Doppelkupplung (PDK, replaces Tiptronic S) with 7 gears tackles the particular challenge of combining the efficiency of a manual transmission with the excellent shifting and driving comfort of an automatic transmission with torque converter and shifting automatically without interrupting the traction. Moreover, the driver is also given the opportunity to shift the gears manually using sliding buttons on the new 3-spoke sports steering wheel for PDK or with the gear selector for PDK, which is also new. The Porsche Doppelkupplung (PDK) consists of a housing accommodating in principle 2 transmissions with 2 clutches, i.e. a double clutch.

Boxster
Boxster S
Cayman
Cayman S

Transmission

3

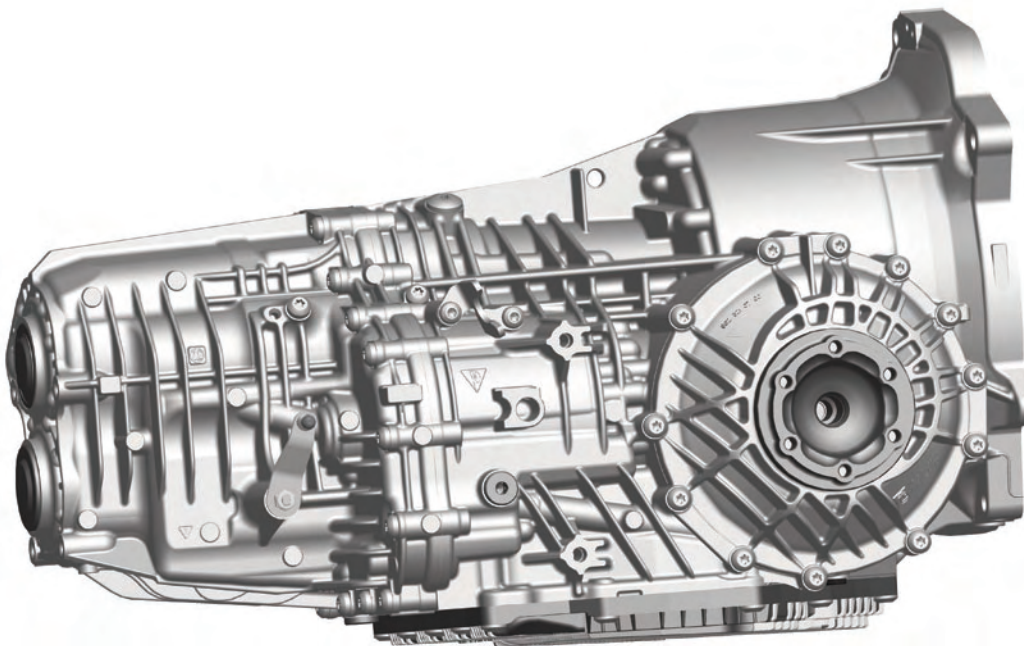

3_66_09

General information	64	Final drive with differential	86
Transmission data	65	Shifting	87
Transmission oils	66	Parking lock	88
Transmission concept	68	Power flow	89
Operation	69	Double clutch	90
3-spoke sports steering wheel for PDK	70	Hydraulic control	93
Gearshift strategy	72	Sensors	97
Special functions	75	Electronic transmission control	102
Basic transmission	80	Manual transmission	103
Synchronization	83		

General information

The Porsche Doppelkupplung (PDK) is both a manual and automatic transmission.

The special feature of the Porsche Doppelkupplung (PDK) is that two gears can always be engaged - one gear is engaged while driving and the next potential gear is already pre-selected.

When shifting, the clutch on the active gear opens while the other clutch engages the pre-selected gear at the same time. This happens under load and so quickly that the power flow is permanently available.

Due to its fast gear changes without any significant interruption in traction, the 7-speed Porsche Doppelkupplung (PDK) offers much better driving dynamics than a conventional manual transmission, with the convenience of an automatic transmission.

The superbly sporty driving dynamics are complemented by a high level of efficiency, which results in reduced fuel consumption compared to a conventional manual transmission in certain driving situations.



Transmission

Transmission data

The transmissions of the basic Boxster and Cayman models as well as the Boxster S and Cayman S are identical.

	Boxster/Cayman	Boxster S/Cayman S
Transmission type	CG2.00	CG2.20
1st gear	11/43 3.91	11/43 3.91
2nd gear	24/55 2.29	24/55 2.29
3rd gear	26/43 1.65	26/43 1.65
4th gear	33/43 1.30	33/43 1.30
5th gear	37/40 1.08	37/40 1.08
6th gear	42/37 0.88	42/37 0.88
7th gear	47/29 0.62	47/29 0.62
Rev. gear	3.55	3.55
Rear wheel-drive	11/34 3.091	11/34 3.091
Spur gear-drive	1.146	1.114
Total rear axle	3.25	3.25
Front axle		
Plate-type limited-slip diff. locking factor	22/27	22/27
Ø clutch 1	202 mm	202 mm
Ø clutch 2	153 mm	153 mm

Oil types/oil fill quantities/oil chambers/change intervals

Due to high shearing strains that occur in the differential, two different oil chambers are used in the Porsche Doppelkupplung (PDK).

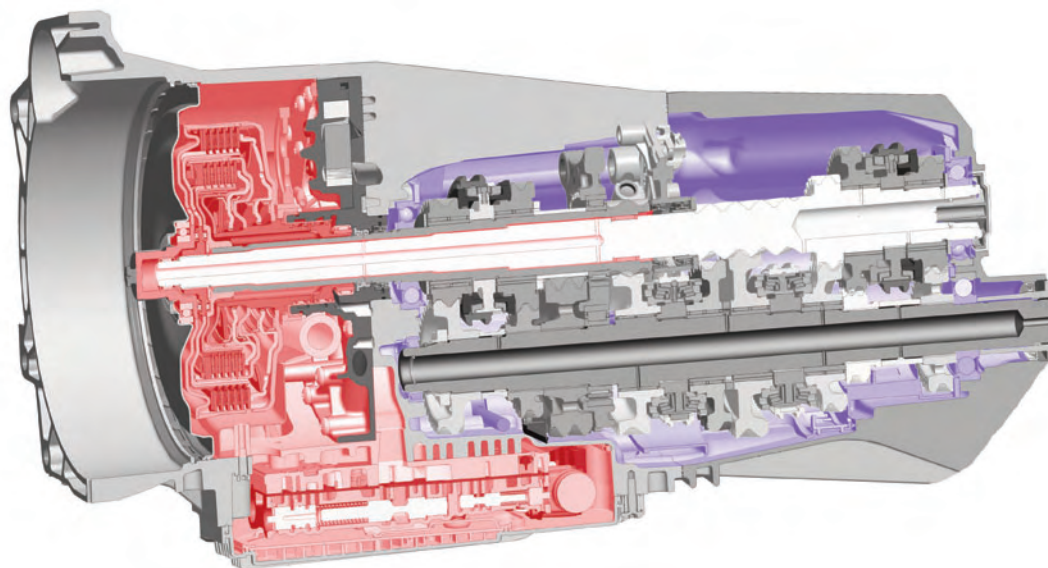

3_65_09

The oil chamber for hydraulic oil is shown in red, while the oil chamber for gear wheel oil is shown in blue in the illustration above.

2.95 liters of Mobilube PTX Formula A (SAE 75W-90) GL4.5 are used in the transmission for lubricating the gear wheel set. 5.2 liters of Pentosin Gear Oil FFL3 are used as hydraulic oil.

The change interval is 56,000 miles (90,000 km) for hydraulic oil and 112,000 miles (180,000 km) for gear wheel oil.



Oil filling

The correct hydraulic oil level is important for operating the transmission without running into problems. The following preconditions must be met in order to check or correct the oil level:

- Engine must be idling
- Vehicle must be horizontal in both longitudinal and transverse axes
- Note hydraulic oil temperature
- Selector-lever position "P"
- Clutch cooling volume flow must be switched off (using PIWIS Tester in Oil fill mode)
- Retain the described states for approx. 1 minute to allow the oil to settle
- Open screw plug on oil overflow bore and collect emerging oil until only drops of oil are emerging
- Once there is no more oil emerging, top up the clutch fluid until oil emerges at the oil overflow bore
- To avoid damaging the clutches, the procedure must be completed within 5 minutes (PIWIS Tester exits Oil fill mode automatically after 5 minutes)

The correct oil level is also important to avoid damaging the gear wheels in the transmission. There is also an overflow bore for this, which is located on the opposite side. The oil level can be checked in the usual way here.

Transmission concept

In principle, a “Doppelkupplung” (double clutch) transmission can be understood as a parallel-switched transmission made up of two fully synchronized shift-sleeve transmissions (transmission 1 and transmission 2).

Each transmission has its own clutch:

- Transmission 1, clutch K1 (outer clutch)
- Transmission 2, clutch K2 (inner clutch)

Transmission 1 switches the odd-numbered gears 1, 3, 5, 7 and reverse gear.

Transmission 2 switches the even-numbered gears 2, 4 and 6.

Basically, only one transmission is ever engaged via the relevant clutch when the vehicle is driving.

- 1 Multiple-disc clutch 1
- 2 Multiple-disc clutch 2
- 3 Transmission 1
- 4 Transmission 2
- A Force input
- B Force output

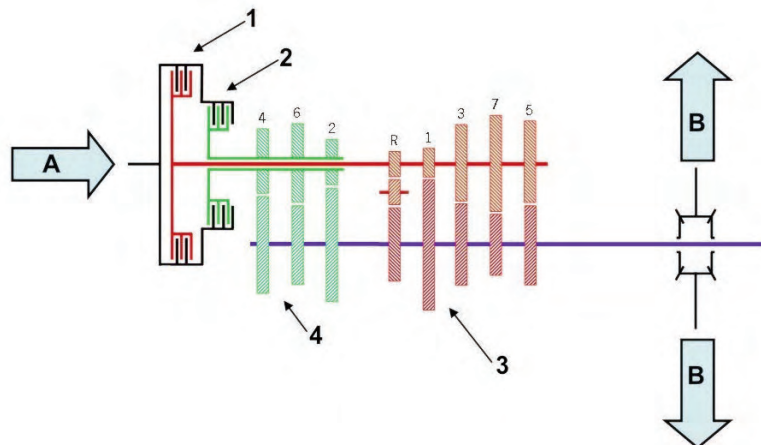

3_58_09b

Operation - general description

Like the Porsche Tiptronic of the previous models, the Porsche Doppelkupplung (PDK) has two selector gates.

In the right-hand gate in selector-lever position "D", upshifts and downshifts are automatic. If the selector lever is moved into the left-hand gate ("M"), upshifts and downshifts can be performed manually. Gears can be changed both on the steering wheel and using the selector lever.

There is no gear lock on vehicles with the Porsche Doppelkupplung (PDK), which means that selector-lever positions P – R – N – D are available.



- P Park
- R Reverse
- N Neutral
- D Drive (automatic shifting:
1st - 2nd - 3rd - 4th - 5th - 6th - 7th
gear)

3_04_09

3-spoke sports steering wheel for PDK



3_67_09

A new 3-spoke sports steering wheel for PDK is used in conjunction with the Porsche Doppelkupplung (PDK) on the new Boxster and Cayman models. This completely redesigned steering wheel has two sliding switches, which are incorporated neatly and conveniently into the steering-wheel spokes. Pressing these switches forward changes up a gear, and pulling them or pressing them towards the driver from the back of the steering wheel changes down a gear. It makes no difference whether the right or the left sliding switch is used for changing gears.

The switches can also be used to activate the “One-touch Hold function” (see Special functions).

Display in instrument cluster for Porsche Doppelkupplung (PDK)

Gearshifts for the new Porsche Doppelkupplung (PDK) are displayed in the instrument cluster. The shift indicator is based on an enhanced Tiptronic S concept. In addition to the usual selector-lever position display (driving mode) via red LEDs, the new instrument cluster also has a numeric gear display.



3_68_09

Other displays in the instrument cluster:

- A flashing selector-lever position in the instrument cluster means that the selector lever is between two positions.
- Transmission temperature too high - prompts the driver to change his driving style. "Warning jerks" can be felt when driving off and the engine power may be restricted. Do not hold the vehicle on a hill, for example, using the accelerator – use the brake pedal instead. Reduce engine load. Stop the vehicle in a suitable place if possible, and allow the engine to run in selector-lever position "N" or "P" until the warning disappears.
- "Transmission emergency run" in white letters means that the vehicle can still be driven, but you should contact an authorized Porsche dealer.
- "Transmission emergency run" in red letters means that the vehicle can only be brought to a stop, after which it can no longer be driven.

Gearshift strategy

The center console includes a SPORT and SPORT PLUS button. The basic gearshift characteristics change, depending on which button is pressed.



3_08_09

Driving in selector-lever position “M”, SPORT and SPORT PLUS button not active

Upshifts and downshifts can be performed both on the steering wheel and using the selector lever. Gearshift comfort is thus adaptive over the entire operating range and adapts to suit the driver's individual driving style. For improved gearshift comfort, the engine torque is reduced while changing gears. Downshifts in deceleration state are accomplished with very little intermediate throttle application and are thus hardly audible. To avoid under-revving and the associated loss of driving comfort, the current gear is switched down to the next-lowest gear at engine speeds of less than approx. 1,200 rpm. An upshift at the engine speed limit only takes place if there is a kickdown in the engine speed limit range (panic shifting). The vehicle always moves off in 1st gear. The Launch Control function (racing start) is not available.

Driving in selector-lever position “M”, SPORT button active

Upshifts and downshifts can be performed both on the steering wheel and using the selector lever. Gearshift comfort is thus adaptive over the entire operating range and adapts to suit the driver's individual driving style, but basic sportiness is increased. The engine torque is reduced only slightly while changing gears. Downshifts in overrun state are accomplished with intermediate throttle application. To avoid under-revving and the associated loss of driving comfort, the current gear is switched down to the next-lowest gear at an engine speed of less than approx. 1,200 rpm. An upshift at the engine speed limit only takes place if there is a kickdown in the engine speed limit range (panic shifting). The vehicle always moves off in 1st gear. The Launch Control function (racing start) is not available.

Driving in selector-lever position “M”, SPORT PLUS button active

Upshifts and downshifts can be performed both on the steering wheel and using the selector lever. Gearshifts are not adaptive and are purely power-oriented, with a corresponding loss of comfort. In addition, the engine torque is not reduced while changing gears. Downshifts in deceleration state involve quick and audible intermediate throttle application with a sporty sound. To avoid under-revving and the associated loss of driving comfort, the current gear is switched down to the next-lowest gear at an engine speed of less than approx. 1,200 rpm. An upshift at the engine speed limit takes place if there is a kickdown in the engine speed limit range (panic shifting). The vehicle always moves off in 1st gear. 7th gear is not used in this program. The Launch Control function (racing start) is also available.

Driving in selector-lever position “D”, SPORT and SPORT PLUS button not active

When the selector lever is moved to position “D”, an extremely intelligent driving programme is activated. Shifting adapts continuously and almost seamlessly to the driving style and route profile over the entire operating range. Gearshifts and gear-changing speeds here are changed from economic/comfortable to sporty. Gearshifts are always performed with more emphasis on comfort. Also for improved comfort, the engine torque is reduced during upshifts and downshifts.

Downshifts in deceleration state and deceleration downshifts are accomplished with very little intermediate throttle application and are therefore hardly audible. The vehicle moves off in 1st gear.

Driving in selector-lever position “D”, SPORT active

An extremely intelligent driving programme is also activated in this position and shifting adapts continuously and almost seamlessly to the driving style and route profile over the entire operating range. Basic sportiness is increased with faster pick-up and slower deceleration. Gearshifts are more power-oriented and the engine torque is only reduced slightly during upshifts and downshifts.

Downshifts in deceleration state and deceleration downshifts are accomplished with intermediate throttle application and are thus audible. The vehicle moves off in 1st gear. 7th gear is avoided for the most part and is engaged only at higher speeds.

Driving in selector-lever position “D”, SPORT PLUS active

Shift map adaptations are not active in this program. The most sporty map is activated permanently.

Gearshifts are power-oriented with reduced gearshift comfort. Downshifts in deceleration state and deceleration downshifts are accomplished with intermediate throttle application and are therefore very audible. Gearshifts are power-oriented and the engine torque is not reduced during upshifts and downshifts. The vehicle moves off in 1st gear. 7th gear is not available. The racing start function is available.

Adaptation of gearshift characteristics to driving style and route profile

Various measured values, such as accelerator pedal position, accelerator pedal change speed, axial and lateral acceleration, vehicle speed and engine speed as well as the steering angle, are used to adapt the gearshift characteristics almost continuously to the driving style and route profile. This adaptation is performed in “Normal” mode (no sport buttons pressed) and sometimes in SPORT mode. No adaptation is performed in SPORT PLUS mode. When this adaptation is selected, the shift program not only takes the driving style into consideration, but also road resistance. Changes in road resistance are particularly noticeable when driving uphill and on downward slopes. In addition, the PDK control unit calculates an altitude correction factor, i.e. since the volumetric efficiency of the engine decreases as the altitude increases, the driver automatically accelerates more and the transmission would switch to a more shift-conducive map. This is detected by the altitude sensor and the optimal map is made available to the driver.

Special functions

- **Launch Control (racing start function)**

This function is available both in selector-lever position “D” and “M” in SPORT PLUS mode. Preconditions are as follows: Vehicle stationary, brake applied, kick-down active. The function is triggered by releasing the brake. The double clutch in the transmission now enables optimum wheel slip at maximum acceleration.

Stress on components increases dramatically when starting with maximum acceleration in comparison to “normal” driving off. In addition, the components in the clutches are exposed to high levels of thermal stress. To protect the components in this case, this function is disabled for a distance of 1.5 miles (2.5 km) after a racing start. During the 1.5 miles (2.5-km) drive, the clutches are cooled at the maximum cooling volume flow.

- **Prevention of downshifts in overrun state, e.g. when approaching a bend (Fast Off)**

If the driver decelerates, i.e. releases the accelerator pedal quickly, when approaching a bend, the currently engaged gear is retained. If the driver also actuates the brake now, downshifts adapted to the vehicle speed are performed so that engine braking support is available when approaching a bend and the vehicle can be accelerated out of the bend in the optimum gear. If the accelerator pedal is now moved towards throttle valve “open” again, gearshifts are performed once again according to the driver’s wishes. This function responds differently, depending on which mode was selected. If “Normal” mode is selected, the function is only activated for a high negative accelerator pedal gradient. In SPORT mode, the function is activated for a medium negative accelerator pedal gradient, while it is activated for a low negative accelerator pedal gradient in SPORT PLUS mode.

- **Downshifts while braking (Fast Back)**

A downshift is initiated immediately if the driver switches quickly (within approx. 1 second) from accelerating to braking. However, the sportiness characteristic and the selected mode dictate how early a downshift is initiated.

- **Gear retention while cornering**

The lateral-acceleration sensor (joint component also incorporating rotationrate sensor), which is located under the center console and works for the PSM system, is used to detect lateral acceleration and retain the engaged gear and lateral acceleration in the relevant gear, depending on the shift map.

- **Active switching to a sporty gear-changing map**

For increased spontaneity, the system switches to a sporty and dynamic shift map when the driver uses fast, positive accelerator pedal movements. The previous map is then activated again afterwards. This function is intended, for example, for situations in which a driver is driving at an extremely comfortable speed on a country road, but now decides to overtake and wants the vehicle to drive dynamically for a short time.

- **Manual momentary intervention in selector-lever position “D”**

To enable manual downshifts even in the automatic gear-selection gate, e.g.:

- when approaching a bend
- when entering villages/small towns
- when driving downhill

the upshift and downshift buttons (both on the steering wheel and on the selector lever) are active in the automatic gear-selection gate. In other words: the Porsche Doppelkupplung (PDK) switches to the manual program when the corresponding button is pressed. “M” appears in the instrument cluster and the requested gearshift is performed. At the same time, an 8-second timer is started in the control unit. If the upshift or downshift button is pressed again within these 8 seconds, the timer is restarted. The Porsche Doppelkupplung (PDK) automatically switches back to Automatic mode (“D” appears in the instrument cluster) if:

- the timer runs out, no cornering is performed and the vehicle is not in deceleration state,
- the selector lever is moved from “D” to “M” and back to “D”.

Automatic upshifts and downshifts at the engine speed limits remain active.

The deceleration downshift function is also active.

Warm-up program

The warm-up map is a shift program with raised gear-changing points, which has the effect of heating the catalytic converters to their operating temperature as quickly as possible. The engine and transmission also reach their operating temperature more quickly with this map. The coolant temperature of the engine is checked when the engine is started. If this is less than approx. 68° F. (20° C), the warm-up program is activated and is deactivated again when the coolant temperature is 86° F. (30° C).

Overheating protection

Various measures are implemented on the transmission in order to protect the transmission and double clutch from overheating. The temperature sensor, which is fitted above the hydraulic control unit and measures the oil sump temperature, is used for this purpose. A calculation model which calculates the clutch temperature from the engine torque and the slip at the clutch, is also used.

Overheating protection is activated in several stages and actively prompts the driver to adapt his driving style.

Clearly perceptible jerking occurs in the first stage due to continuous opening and closing at drive-off and crawling speed, thereby prompting the driver to change the driving situation. Engine torque and kickdown revs are also reduced.

This is not displayed in the instrument cluster. A fault is stored in the control unit. If the temperature continues to rise, stage two is activated. This means that jerking continues. The engine torque and kickdown revs are reduced more drastically in this case. The white warning "Transmission temperature too high" appears in the instrument cluster and another fault is stored in the fault memory.

If the temperature rises even further, the red warning "Transmission emergency run" appears in the instrument cluster. A short time later, the double clutch is opened completely and power transmission is no longer available. Another fault is stored in the fault memory. If the driver now presses the accelerator, the vehicle will drive off, but not with the usual level of comfort. After implementing these measures, the transmission activates a special shift program in which gear changes are performed very slowly and uncomfortably. Once the temperature falls below a certain temperature threshold, the transmission reverts to its normal program.

Upshift suppression for 7th gear

7th gear is designed as an overdrive on the Porsche Doppelkupplung (PDK). This means that in various driving situations, e.g. high road resistance, the vehicle would decelerate when 7th gear is engaged. As a result, 7th gear is not engaged in such situations.

Upshift interruption

In automatic transmissions, the time that elapses between triggering a change in speed and starting to change speed is called the response time. Naturally, this response time depends on the shift programme and the gearshift characteristic. During this time, the driver does not yet notice that the gearshift operation has already started. If the driver's intention changes, e.g. the driver quickly eases off the accelerator, the upshift that has started is interrupted provided the engine speed remains unchanged.

One-touch Hold function

The one-touch button on the steering wheel or the selector lever must be held in a downshift ("-") or upshift direction ("+") in order to engage the lowest or highest possible gear in the manual gate. Tipping the button back initially triggers the first gear change in accordance with the touch command. The next-lowest next-highest gear is then always engaged by holding the button. This saves the driver from having to touch the button repeatedly. This function is switched off after 25 seconds to prevent malfunctions.

Crawling

To ensure that the Porsche Doppelkupplung (PDK) transmission behaves in the same way as a Tiptronic transmission when driving off, clutch 1 is already slightly engaged so that the transmission becomes positively engaged and must be held by the brake.

Another advantage of this measure is that the vehicle drives off very comfortably and generally smoothly when only a light load is applied. Driving off at a higher load results in higher drive-off power.

Stationary decoupling

When the vehicle comes to a stop, the clutch is generally opened as long as the brake is applied. However, the clutch remains slightly engaged in order to take full advantage of crawling. The reason for this measure is reduced fuel consumption.



Transmission

3

Drive-Off Assistant

If the vehicle is stopped on an incline, the driver will apply the brake and set a certain brake pressure. When the driver now switches from the brake pedal to the accelerator pedal in order to drive off, the set brake pressure is maintained for as long as it takes for the vehicle to drive off. This prevents the vehicle from rolling back while the driver is switching pedals. Rollback prevention is enabled for max. 2 seconds.

Tow-starting/towing

The vehicle cannot be tow-started, nor should this be attempted due to the risk of serious transmission damage. When the engine is not running, adequate lubrication of the transmission is not guaranteed. Therefore the following points must be observed:

1. Engage selector-lever position "N"
2. Top speed = 30 mph (50 km/h)
3. Maximum towing distance = 30 miles (50 km)

- 1 Drive shaft 1
- 2 Drive shaft 2
- 3 Main shaft
- 4 Pinion shaft
- 5 Intermediate gear wheel, reverse

Basic transmission

Gear wheel set

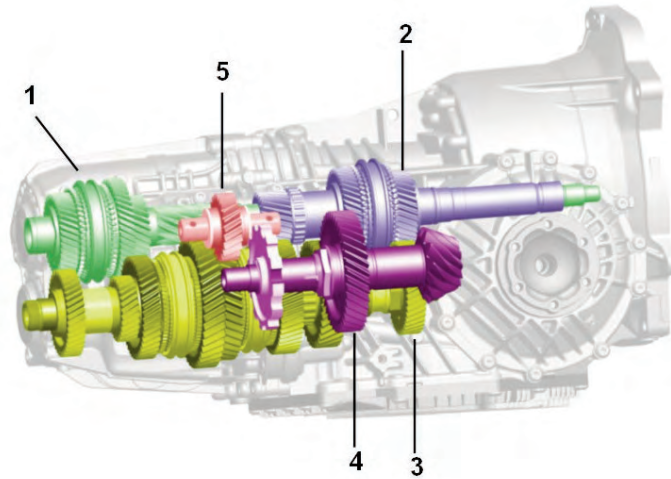

3_69_09

The gear wheel set in the transmission comprises input shaft 1 (1), input shaft 2 (2), the main shaft (3), the pinion shaft (4) and the intermediate gear wheel (5). 1st, 3rd, 5th, 7th and reverse gear are on input shaft 1, while 2nd, 4th and 6th gear are on input shaft 2.

- 1 Sensor wheel
- 2 Fixed gear wheel for reverse
- 3 Fixed gear wheel for 1st gear
- 4 Fixed gear wheel for 3rd gear
- 5 Loose gear wheel for 7th gear
- 6 Synchronizing hub with synchronization
- 7 Loose gear wheel for 5th gear

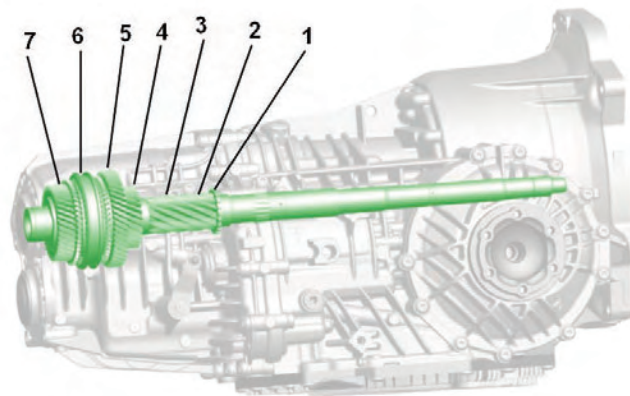

3_70_09

The illustration above shows the structure of input shaft 1.

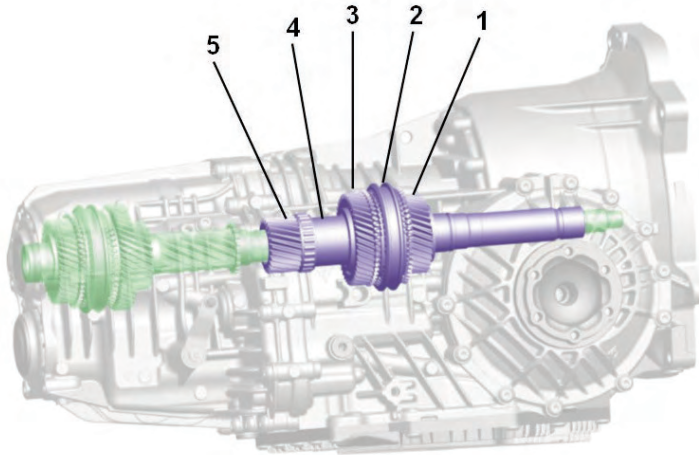

3_71_09

The illustration above shows the structure of input shaft 2.

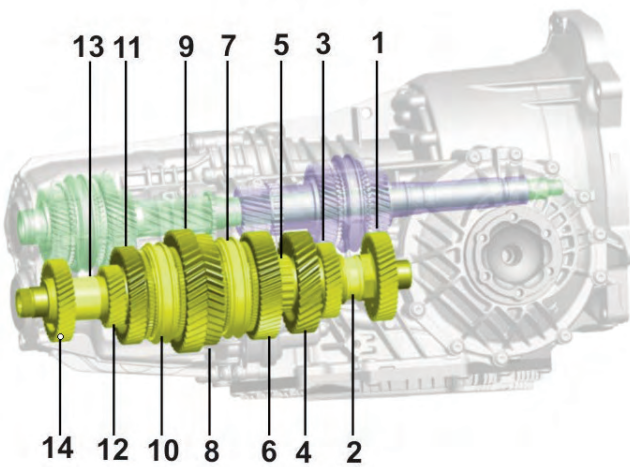

3_72_09

- 1 Loose gear wheel for 4th gear
- 2 Synchronizing hub with synchronization
- 3 Loose gear wheel for 6th gear
- 4 Spacer
- 5 Fixed gear wheel for 2nd gear

- 1 Fixed gear wheel for 4th gear
- 2 Spacer
- 3 Fixed gear wheel for 6th gear
- 4 Constant gear wheel
- 5 Bearing plate bearing
- 6 Loose gear wheel for 2nd gear
- 7 Synchronizing hub with synchronization
- 8 Loose gear wheel for reverse gear
- 9 Loose gear wheel for 1st gear
- 10 Synchronizing hub with synchronization
- 11 Loose gear wheel for 3rd gear
- 12 Fixed gear wheel for 7th gear
- 13 Spacer
- 14 Fixed gear wheel for 5th gear

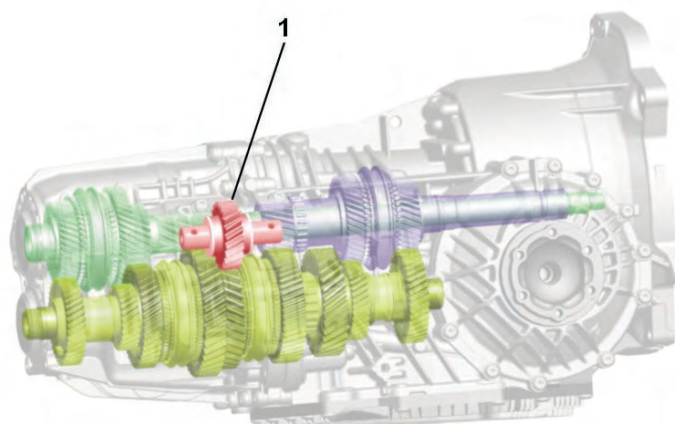

3_73_09

The direction change for reverse gear is accomplished via an intermediate gear wheel (1), which is located between input shaft 1 and the main shaft.

- 1 Bevel gear
- 2 Constant gear wheel
- 3 Parking-lock gear

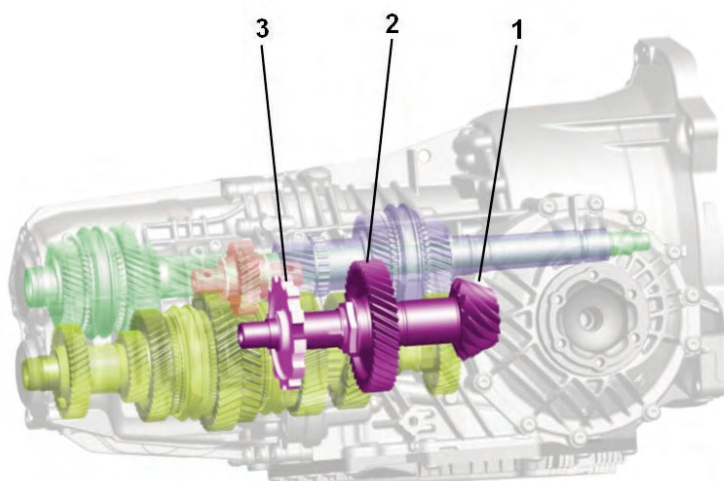

3_74_09

Synchronization

Basic operating principle of servo-lock synchronization

Synchronization in neutral position. The ball (2) holds the operating sleeve (5) in neutral.

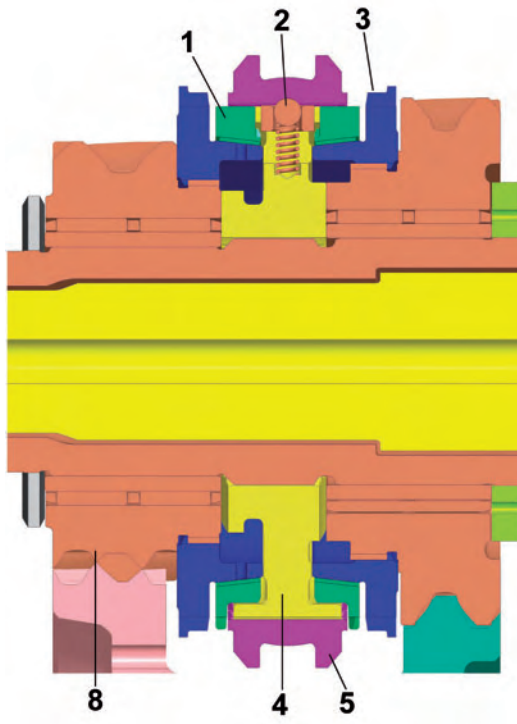

3_18_09

When changing gears, the operating sleeve (5) is moved (to the left in the example shown) using the shift fork of the selected gear. The operating sleeve presses the synchroniser ring (1) against the friction cone of the clutch hub (3) via the pressure piece (7). At this moment, the synchronizer ring turns until it reaches a stop (not shown in the illustration). This blocks the movement of the operating sleeve.

- 1 Synchroniser ring
- 2 Ball
- 3 Clutch hub
- 4 Guide sleeve
- 5 Operating sleeve
- 6 Spring
- 7 Pressure piece
- 8 Loose gear wheel

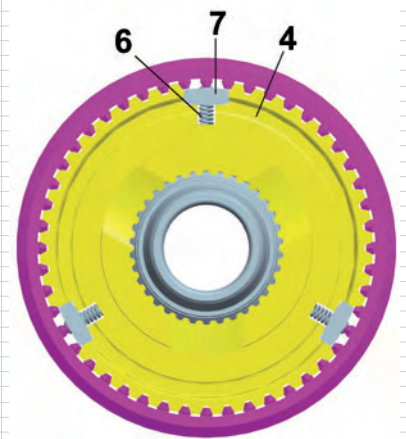

3_17_09

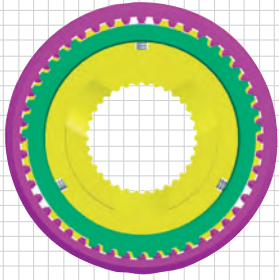

3_22_09

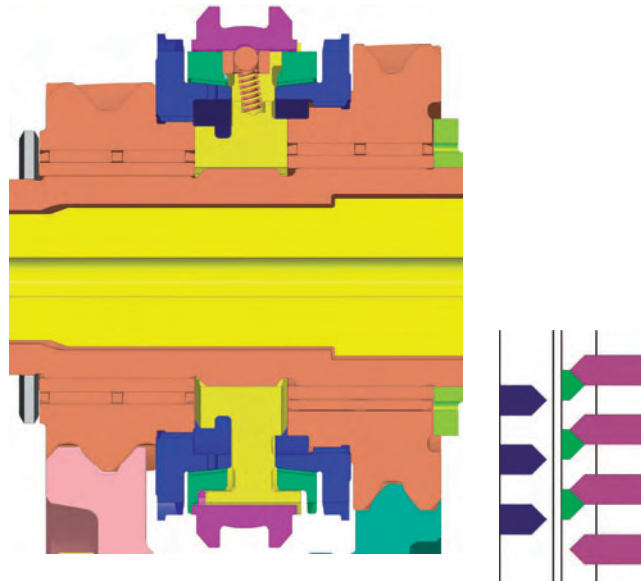

3_21_09

The synchronizer ring (1) continues to block the operating sleeve for as long as there is a difference in speed between the clutch hub (3) and operating sleeve. The synchronizer ring can only be turned back through the operating sleeve when the speed is the same. The latter is then moved on slightly to the clutch hub. The gear is engaged.

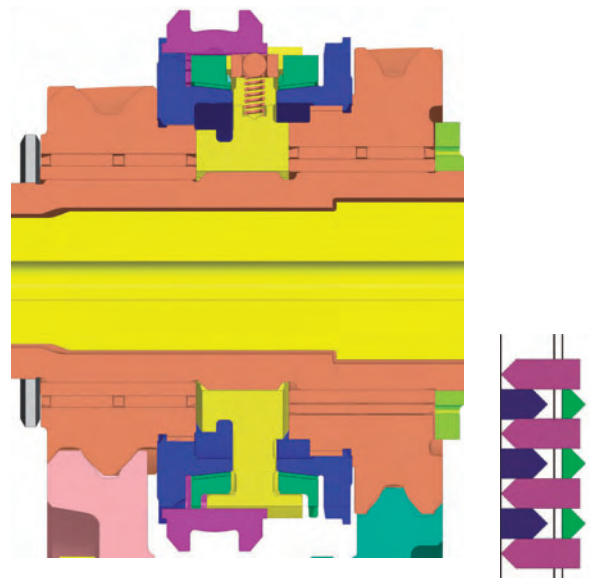

3_24_09



Transmission

3

Synchronization of reverse, 1st, 2nd and 3rd gear

Triple cone synchronizer is used for reverse, 1st, 2nd and 3rd gear. The use of three friction cones has resulted in a considerable reduction in synchronizing forces. This reduces shifting forces when engaging gears. The first friction cone comprises the friction cone of the clutch hub of the loose gear wheel (2) and the inner cone of the inner ring (4). The second friction cone comprises the outer cone of the inner ring (4) and the inner cone of the intermediate ring (3). The third friction cone comprises the outer cone of the intermediate ring (3) and the inner cone of the synchronizer ring (1).

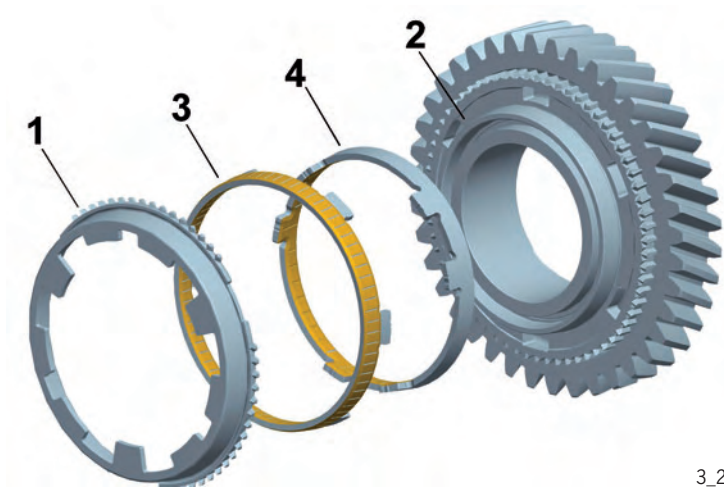

3_26_09

- 1 Synchronizer ring
- 2 Friction cone for loose gear wheel
- 3 Intermediate ring
- 4 Inner ring

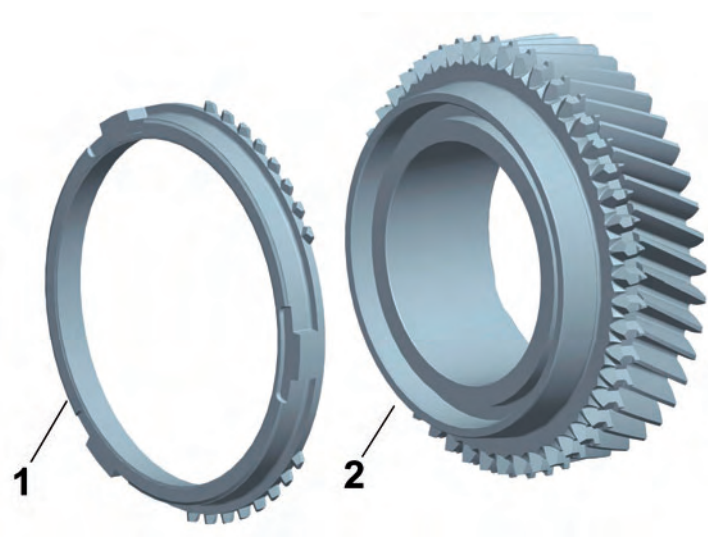

3_27_09

- 1 Synchronizer ring
- 2 Friction cone for loose gear wheel

Synchronization of 4th, 5th, 6th and 7th gear

Single cone synchronization is used for 4th, 5th, 6th and 7th gear. The cones from the clutch hub (2) and the cones of the synchronizer rings (1) form the friction cone.

- 1 Cover
- 2 Flange
- 3 Ring gear
- 4 Differential
- 5 Pinion shaft

Final drive with differential

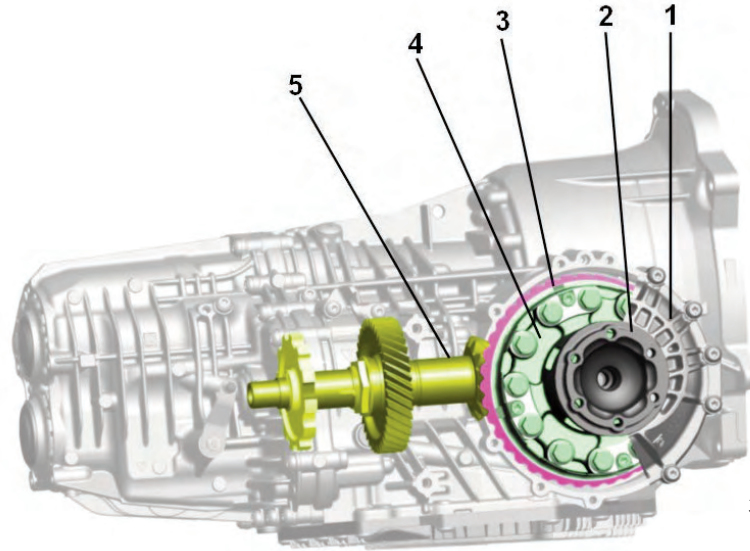

3_75_09

The illustration above shows the position of the final drive in the transmission.

- 1 Ring gear
- 2 Differential pinions
- 3 Shaft bevel gears
- 4 Planet-gear carrier
- 5 Discs
- 6 Pinion

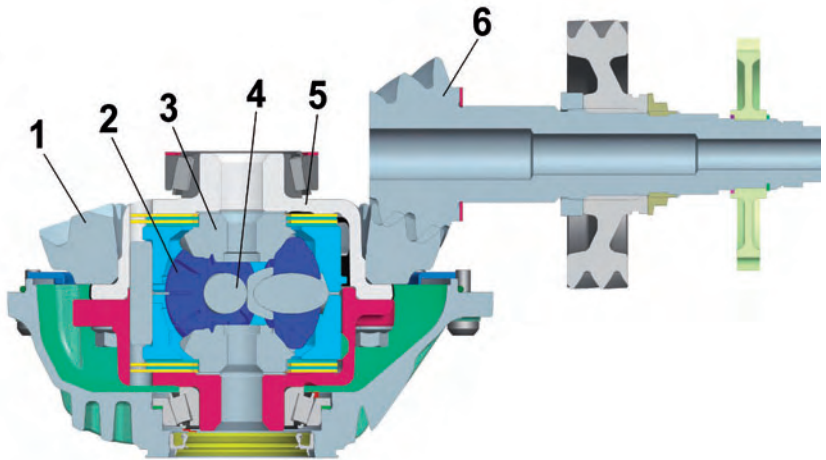

3_42_09

The final drive is designed as a hypoid drive. A limited-slip differential with a lock value of 22% in traction and 27% in overrun is available as an optional item of equipment instead of the standard differential.

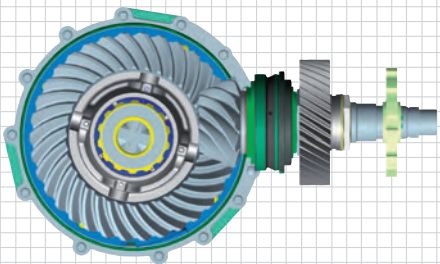

3_43_09

Shifting

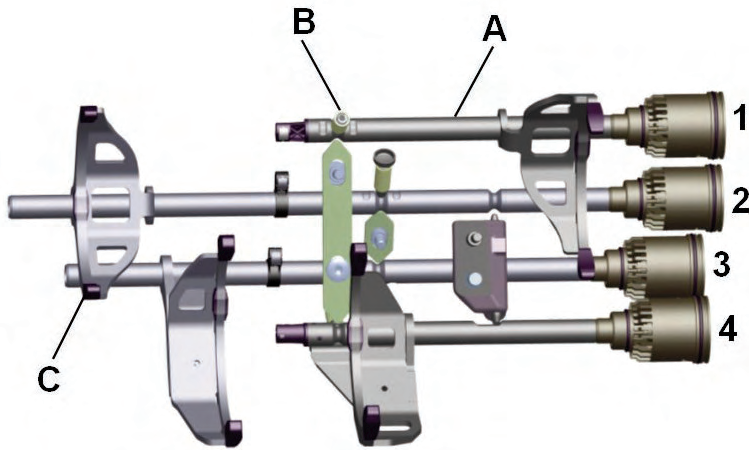

3_76_09

- 1 Shift rod for gears 4 and 6
- 2 Shift rod for gears 5 and 7
- 3 Shift rod for gears 1 and 3
- 4 Shift rod for gears 2 and reverse
- A Shift rod
- B Magnet
- C Shift fork

The shift rods are actuated hydraulically and are used to switch the synchronizers and thus to change gears. They transfer the shifting forces generated in the actuator hydraulics to the actuating elements for synchronization. Each shift rod actuates two synchronizers and thus two gears. Once the gear is engaged, the shift rod is depressurized. The gear is held securely and without strain by detent in traction/deceleration mode by positive engagement of the tothing.

The shift rods are locked in neutral and the end positions. Shift travel from neutral into the locked engage positions of the gears is nominally the same for all shift rods. The mechanical neutral position is nominally 0 mm shift travel, in accordance with the characteristic of the transmission displacement sensors. Each shift rod has a sensor magnet for recording shift travel via the transmission distance sensors.

Locking

The shift rods in a transmission are locked against each other. In transmission 1, shift rod 3 (1st/3rd gear) is locked against shift rod 2 (5th/7th gear).

In transmission 2, shift rod 1 (4th/6th gear) is locked against shift rod 4 (2nd/reverse gear). Reverse gear is also locked against all forward gears.



3_29_09

Parking lock

Even if the vehicle is in gear, it cannot be prevented from rolling back in the same way as with a manual transmission because the clutches are opened in depressurized state and therefore do not stop the vehicle from moving. The parking lock prevents the vehicle from rolling away, as with an automatic transmission.

When the vehicle is stationary, the parking lock is engaged (purely mechanically) using the selector lever and blocks the pinion shaft via a catch which engages in the toothing of the parking-lock gear. The final drive is blocked in this way.

- 1 Selector shaft
- 2 Parking-lock gear
- 3 Catch

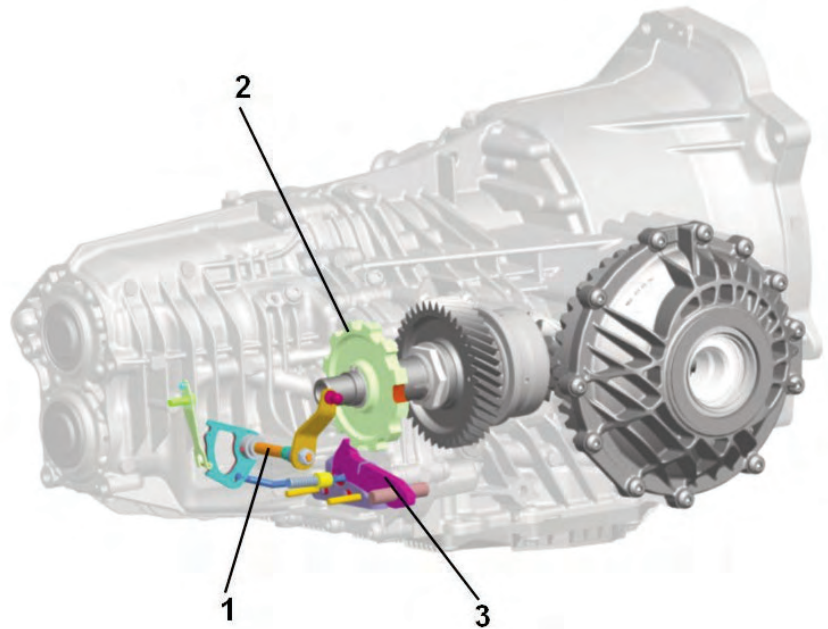

3_77_09

- 1 Detent spring
- 2 Selector shaft
- 3 Detent disc
- 4 Connecting rod
- 5 Catch
- 6 Leg spring
- 7 Parking-lock gear

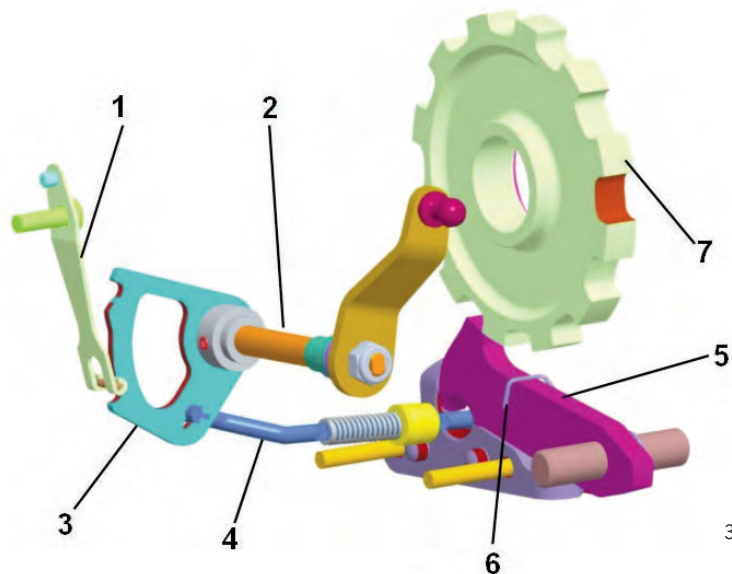

3_78_09

Power flow

The torques are transferred either via clutch 1 or 2. Clutch 1 drives input shaft 1 (inner input shaft) and clutch 2 drives input shaft 2 (outer input shaft).

1st, 3rd, 5th, 7th and reverse gear are on input shaft 1, while 2nd, 4th and 6th gear are on input shaft 2.

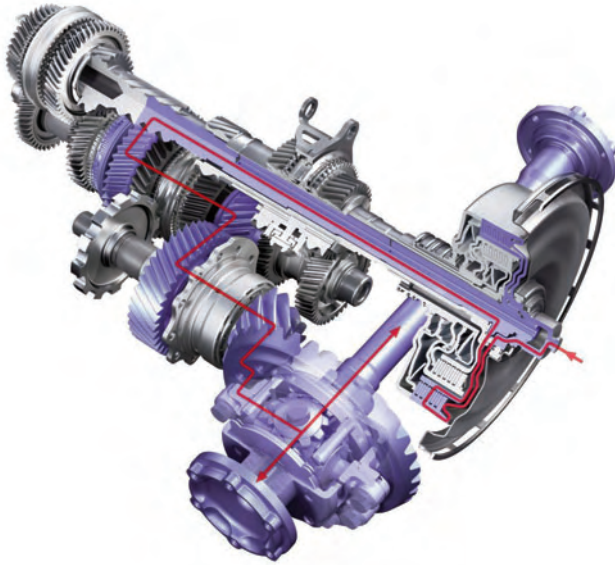

3_79_09

Example of power flow for 1st gear

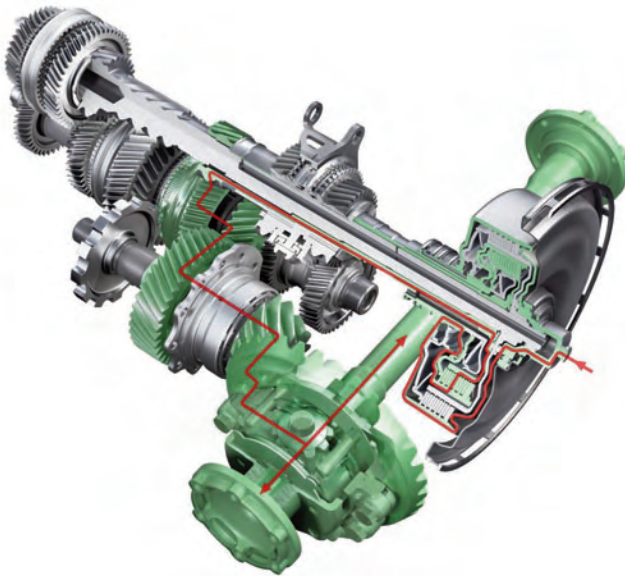

3_80_09

Example of power flow for 2nd gear

Dual-mass flywheel

The engine torque is transmitted into the clutches via a dual-mass flywheel.

Double clutch

The wet double clutch is a central module of the Porsche Doppelkupplung (PDK). With its wide range of technical features, it implements the functional requirements of the transmission control system, thereby shaping the special character of this transmission concept.

Very fast response times, low inertia and good, comfortable friction values, combined with good economy allow both very sporty driving with highly dynamic gear changing as well as comfortable cruising.

For safety reasons, the clutches are open when they are depressurised and inactive.

The radial arrangement of the disc packs provides the best combination from the point of view of performance and space.

- 1 Outer disc carrier (engine speed)
- 2 Disc pack, transmission 2
- 3 Hydraulic actuation, transmission 2
- 4 Input shaft, transmission 2
- 5 Connection to engine
- 6 Input shaft, transmission 1
- 7 Hydraulic actuation, transmission 1
- 8 Disc pack for transmission 1

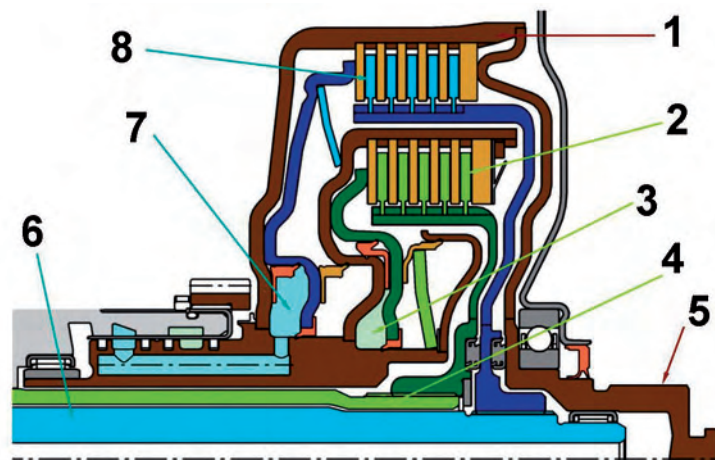

3_40_09

Careful selection of pad type, pad dimensions and usage as well as uniform distribution of thermal load and oil flow in the disc pack, along with the corresponding oil types, are prerequisites for comfort and performance over the service life.

Low drag torques even at low temperatures as well as good resistance at high speeds guarantee comfort and excellent sportiness, but are also important safety requirements.

Function

The double clutch is positioned directly at the transmission input. It transfers the engine torque from the dual-mass flywheel via the profile of its input shaft and passes it through the housing cover of the dry chamber into the wet chamber and on to the primary side of the clutch.

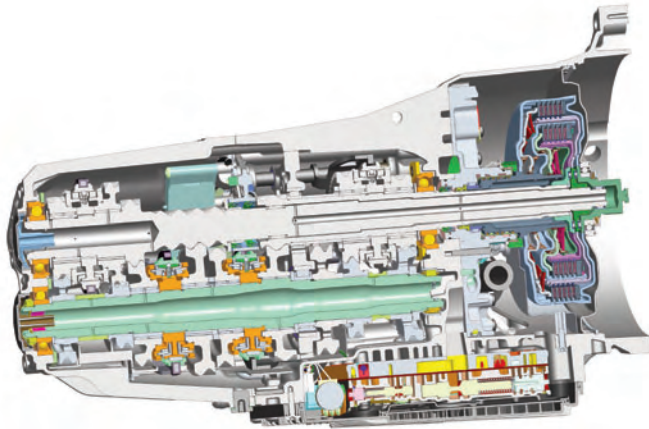

3_81_09

The disc packs are arranged radially over each other. The clutch sends the torque either to the odd gears 1st, 3rd, 5th and 7th and to reverse gear via the outer disc pack, or to the transmission with 2nd, 4th and 6th gear via the inner disc pack, depending on which of the two is activated by the control pressure of the hydraulic transmission control system.

The torque is relayed to the two transmissions via the profiles of the transmission input shafts.

Special hydraulic oil is used for actuating the double clutch hydraulically and for cooling the clutch. This oil is also used for shifting gears. The Porsche Doppelkupplung (PDK) has a separate oil circuit for lubricating the gear wheel set and for cooling. This oil must not be mixed with hydraulic oil.

Both clutches can be actuated and operated with slip regulation independently of each other.

Both clutches display slight centrifugal force overcompensation. The double clutch is not fully slip-regulated in any operating state, which means that the vehicle must be held with the brake when in gear to prevent it from rolling away.

Clutch cooling

- K1 Cooling duct for clutch 1
- K2 Cooling duct for clutch 2
- Q_kühl Cooling duct cross-section (regulated)
- „0“ Cooling duct closed

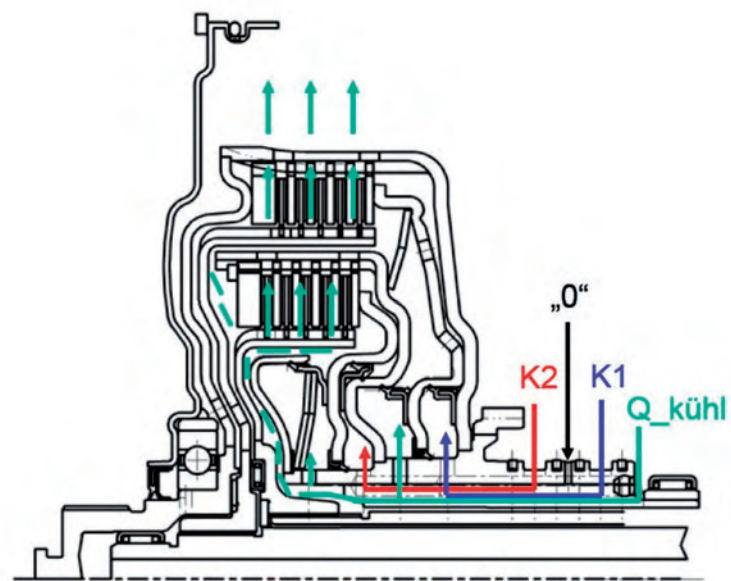

3_40_09a

The clutches are cooled with a separate oil flow to prevent them from overheating. Clutch cooling and clutch control are activated at the same time. The cooling volume flow is regulated between 0 and approx. 40 litres/minute as required by a control valve on the hydraulic control unit.

Hydraulic control

The hydraulic switching device performs the following tasks:

- Controls the system and reducing pressure
- Supplies oil to the actuators, clutches, actuating cylinders, cooling system and lubrication system
- Activates the clutches and actuating cylinders
- Provides emergency hold functions in mechanical transmission limp-home mode
- Controls the parking lock hydraulically

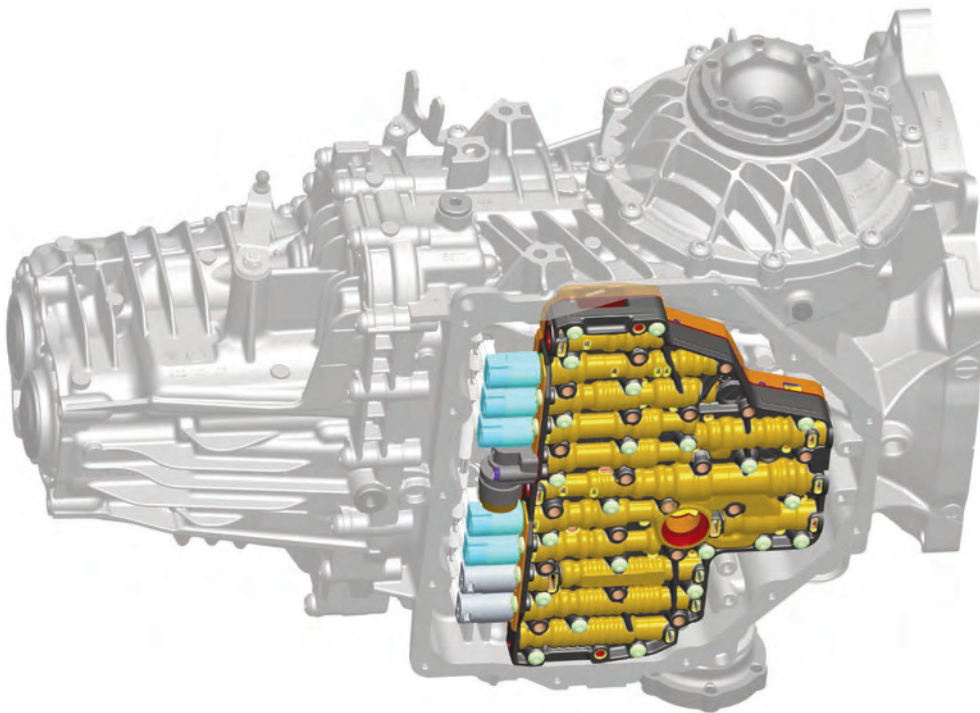

3_82_09

The hydraulic system is installed in the oil pan area in the transmission.

Boxster
Boxster S
Cayman
Cayman S

Transmission

3

- 1 Centering bore B
- 2 Locking groove
- 3 Pass-through screws (20)
- 4 Centering bore
- 5 Clamp
- 6 Oil discharge for temperature sensor
- 7 Pressure regulator
- 8 Solenoid valves

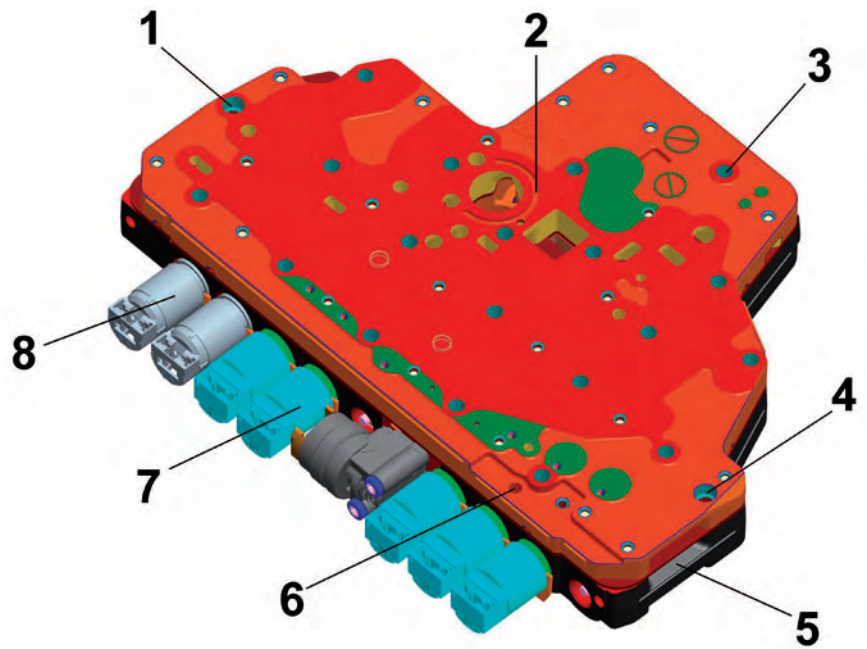

3_45_09

- 1 Clamp
- 2 Port plate
- 3 Intermediate plate
- 4 Valve housing
- 5 M6 bolts in hydraulic switching device (22)
- 6 M6 through bolts (20)
- 7 Retaining bracket
- 8 Solenoid valves
- 9 Pressure regulator

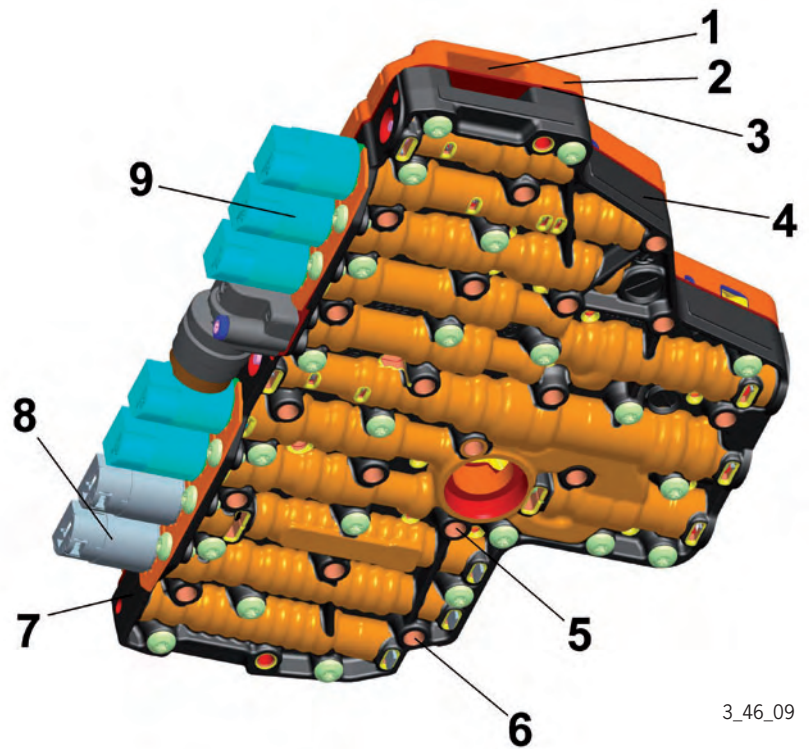

3_46_09

Boxster
Boxster S
Cayman
Cayman S

Transmission

3

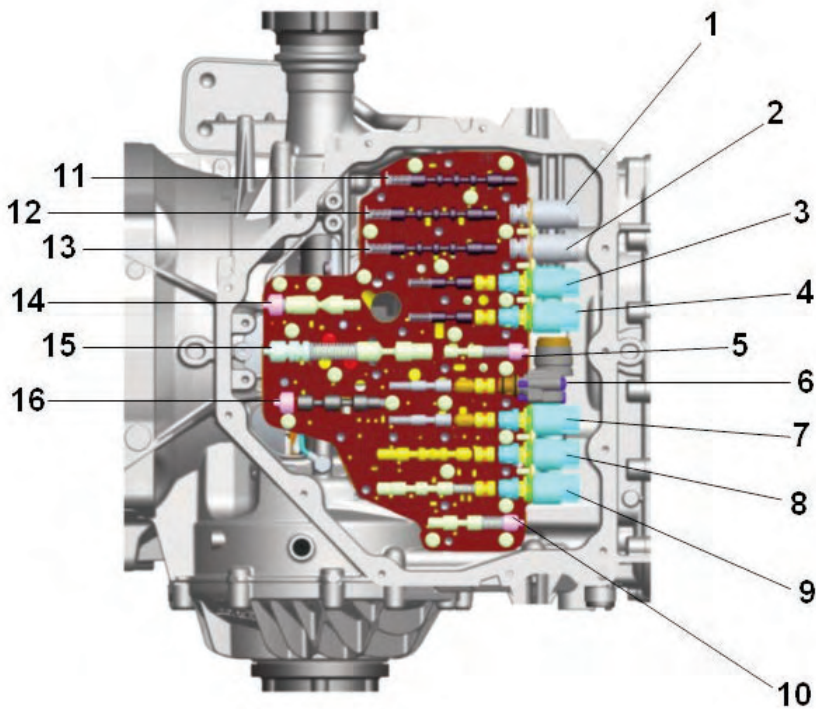

3.83_09

- 1 Solenoid valve 1
- 2 Solenoid valve 2
- 3 Gear valve 2 (EDS5)
- 4 Gear valve 1 (EDS6)
- 5 Pressure reducing valve
- 6 Clutch valve 1 (EDS1)
- 7 Clutch valve (EDS2)
- 8 Clutch selector valve (EDS3)
- 9 Pressure control valve (EDS4)
- 10 Switch-over valve
- 11 Cylinder selection valve 2
- 12 Transmission selection valve
- 13 Cylinder selection valve 1
- 14 Pressure control valve (cooler)
- 15 System-pressure valve
- 16 Cooling valve

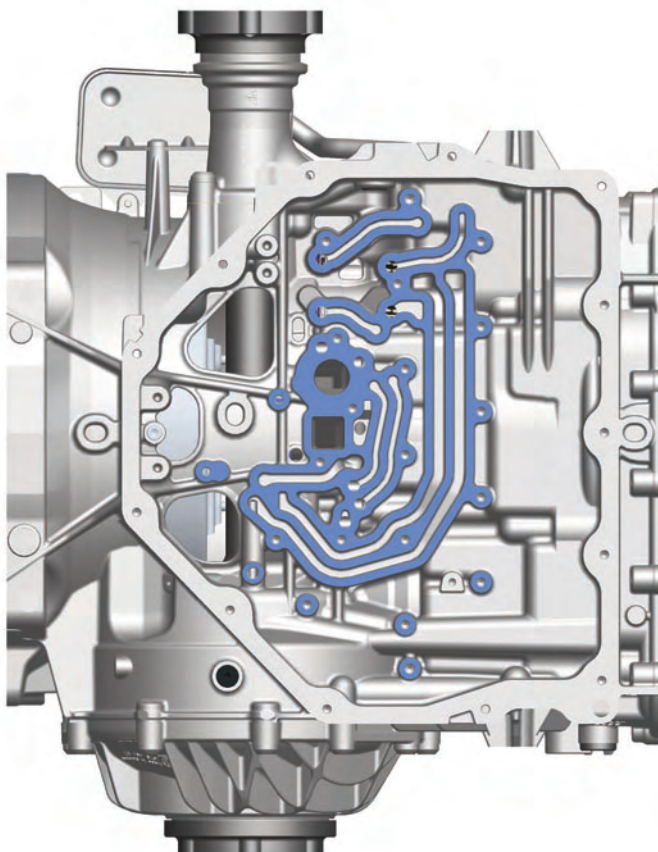

3.84_09

Oil cooler

The oil cooler is fitted on the outside of the transmission. It cools the clutch fluid and hydraulic oil, which is heated up significantly more than gear-wheel oil as a result of operating the clutch (frictional heat).

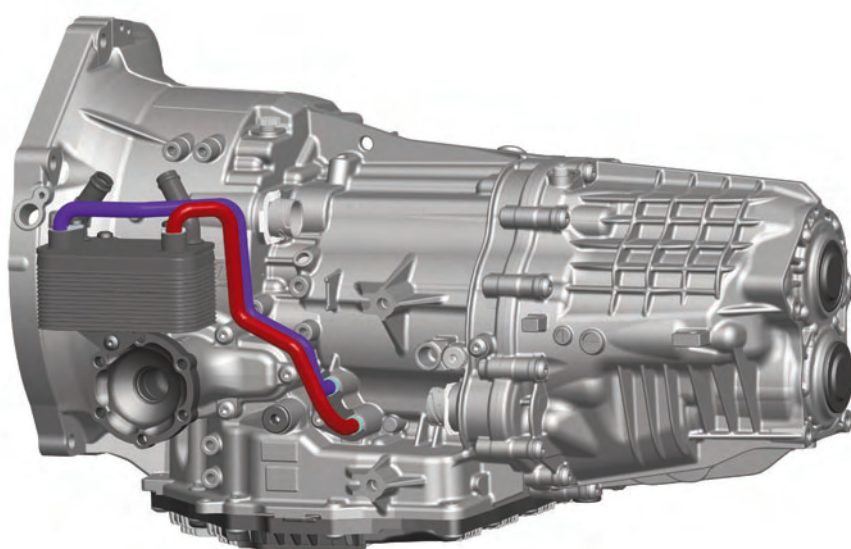

3_85_09

- 1 Oil cooler (oil/water heat exchanger)
- 2 Cooler supply line
- 3 Cooler return line

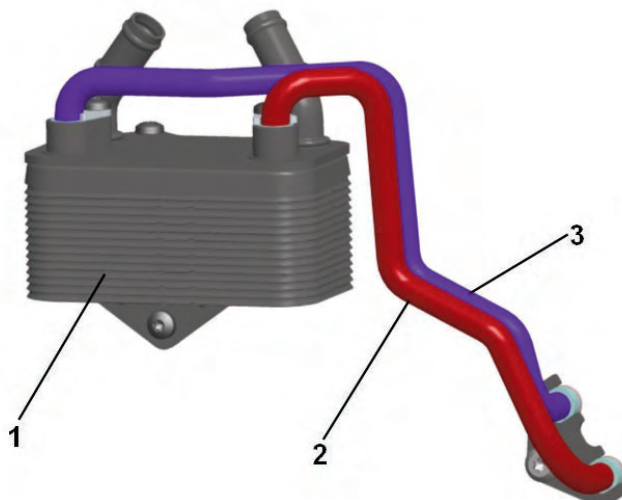

3_86_09

The gear-wheel oil is cooled sufficiently by the transmission housing.

Sensors

The following sensors are used in the transmission for recording speed, temperature, pressure and distance signals.

- 4 distance sensors (combined in one housing)
- 2 rpm sensors (combined in one housing)
- 2 pressure sensors
- 1 temperature sensor

The distance and rpm sensors are connected by a wire harness and their lines are led outwards via the 16-pin transmission connector.

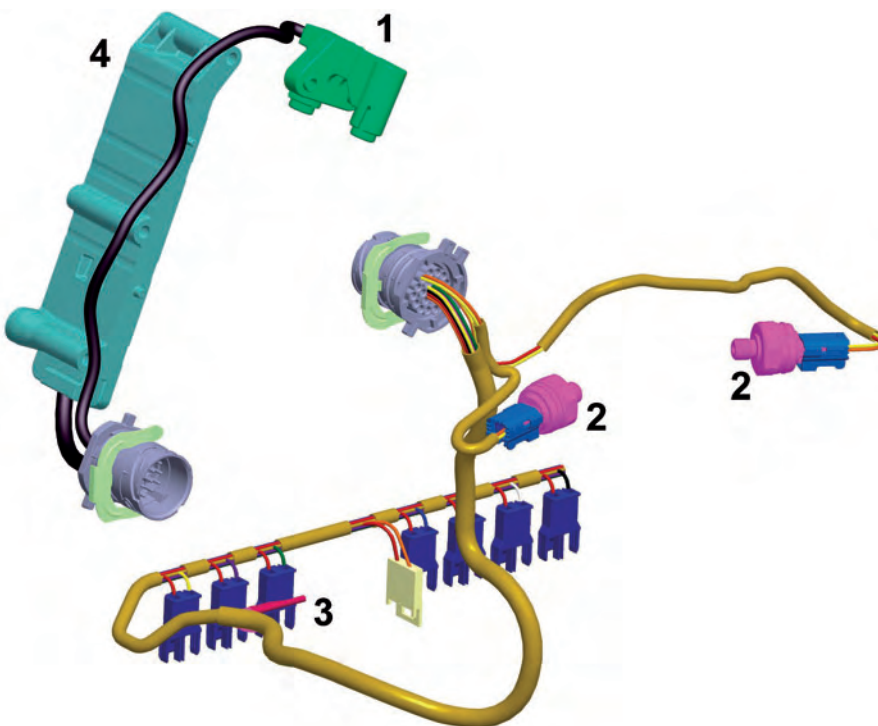

- 1 rpm sensors
- 2 Pressure sensors
- 3 Temperature sensor
- 4 Distance sensors

3_52_09

The pressure sensors (2) are connected to the wire harness, to which the solenoid valves and pressure adjusters are connected. The temperature sensor (3) is connected permanently to the wire harness. The wiring of this sensor is led out of the transmission via a 20-pin connector.

The sensors are all located in the transmission. Sensors cannot be removed or installed from outside.

Distance sensors

The distance sensor unit (also called “sensor tower”) is used for recording the position of each individual shift rod (1). It is designed as an assembly, made up of 4 integrated absolute distance sensors.

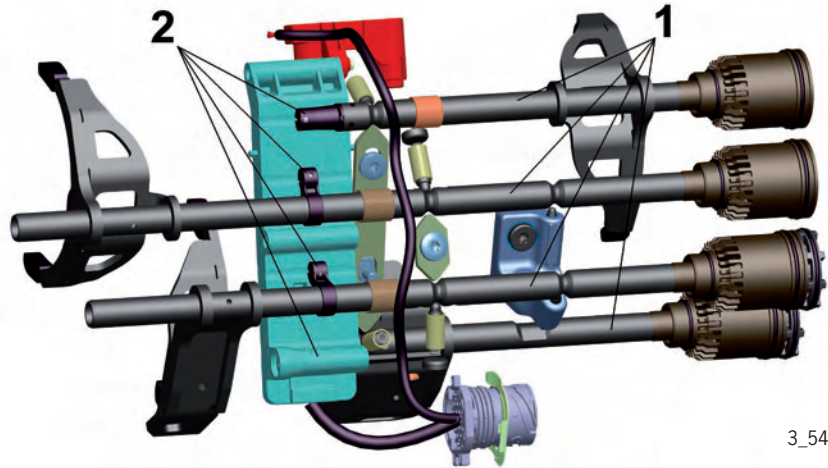

3_54_09

Each shift rod (1) is assigned a sensor, which converts the linear movement of the shift rod into a distance-proportional PWM signal. Other functional components of the distance sensor unit include four associated sensor magnets (2) on the shift rods. The supply voltage for the distance sensors is 5 volts.

The diagnostic system checks the sensor as follows:

- Short circuit to ground
- Short circuit to supply voltage
- Open circuit in line
- Signal plausibility

rpm sensors

The rpm sensors (1) record the transmission input speeds and rotation directions for input shafts 1 and 2. They are designed as an assembly made up of two individual rpm sensors in one housing. The sensor wheel (2) records the speed of input shaft 1, while the fixed gear wheel for 2nd gear records the speed of input shaft 2. A coded PWM signal is generated as the output signal.

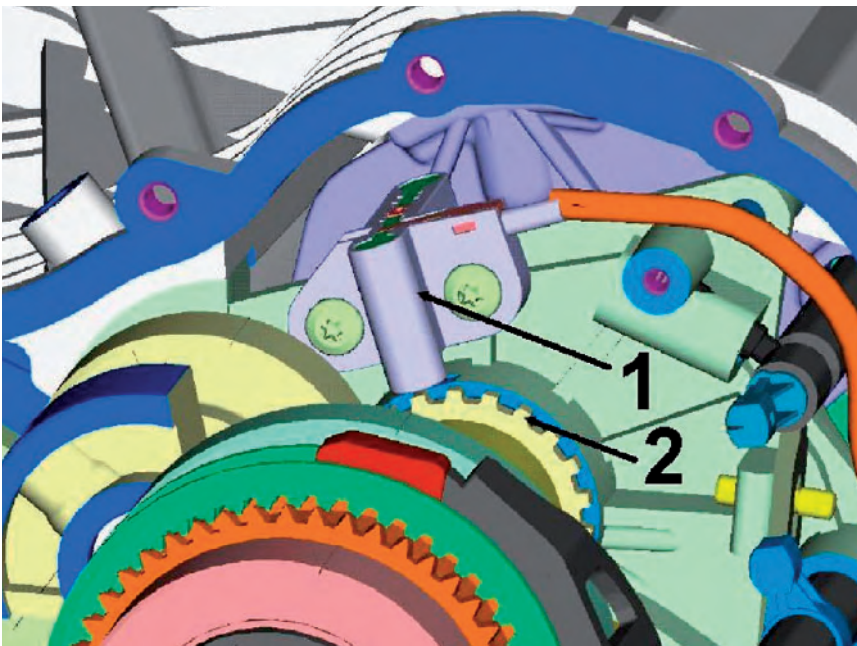

3_55_09

The supply voltage for the rpm sensors is 8.5 volts.

The diagnostic system checks the sensor as follows:

- Short circuit to ground
- Short circuit to supply voltage
- Open circuit in line
- Signal plausibility

Pressure sensors

The two pressure sensors (1) for measuring the clutch pressure values of the two Porsche Doppelkupplung (PDK) clutches are read directly at the rotary transmission feed-through point. They are fitted in the centring plate and are connected to the wire harness (3) by connectors (2).

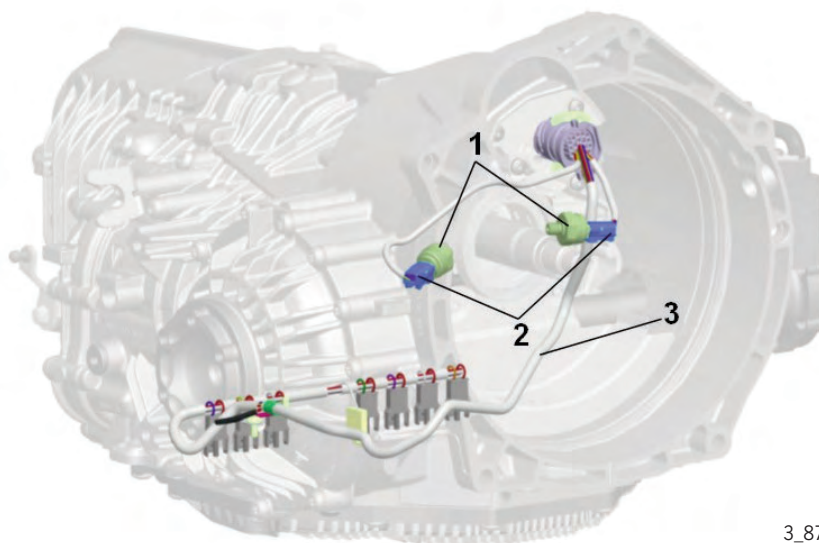

3_87_09

The supply voltage is 5 volts.

The diagnostic system checks the sensor as follows:

- Short circuit to ground
- Short circuit to supply voltage
- Open circuit in line
- Signal plausibility

Temperature sensor

The temperature sensor is used to record the sump temperature of the hydraulic oil. This involves measuring a temperature-dependent resistance.

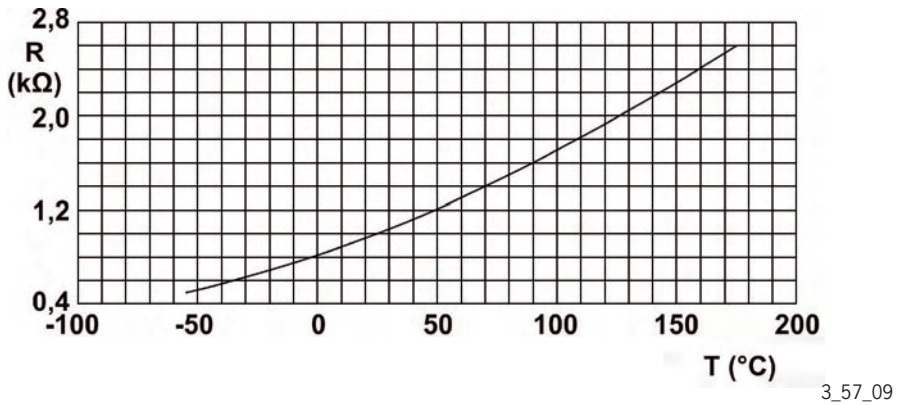

The supply voltage is 5 V.

The diagnostic system checks the sensor as follows:

- Short circuit to ground
- Short circuit to supply voltage
- Open circuit in line
- Signal plausibility

Electronic transmission control

The transmission control unit is connected to other control units in the vehicle via the CAN bus.

The control unit receives information about the driver's wishes, comprising the following items:

- Selector-lever position
- SPORT button and/or SPORT PLUS button
- Accelerator-pedal position
- Brake signal

In addition, the operating state of the vehicle is also input:

- Wheel speeds
- Vehicle speed
- Road resistance
- Axial and lateral acceleration
- Altitude factor
- Engine and transmission speed
- Engine and transmission temperature

These input values are processed in the driving software and the driver's wishes are carried out, depending on the shift program and driver type detection.



3_88_09

The transmission control unit is located in the rear right of the luggage compartment beneath the cover.

Manual transmission

Clutch

Power is transmitted between the engine and transmission via a single-plate dry clutch and dual-mass flywheel. The pressure plate consists of GGG 60 nodular cast iron and has a diameter of 240 mm.

The S models, like the 911 Carrera S vehicles, are equipped with a self-adjusting X-Tend clutch. This clutch registers a reduction in pad thickness and balances the gap difference as a result of pad wear by turning a setting collar. This has the advantage of reducing the increase in force over the service life and up to the wear limit by approx. 50% compared to a conventional clutch. The exact function is described in the Technical Service Information for the 911 Carrera S, model year 2005.

The Boxster and Cayman models with manual transmission feature a shift indicator in the instrument cluster to reduce fuel consumption.

Manual transmission

All new Boxster and Cayman models come with a 6-speed manual transmission as standard.

Based on the 6-speed manual transmission of the previous models, the geometric connection has been modified and the transmission has been adapted in accordance with the increased performance figures of the new generation of engines. The following features have been reworked and enhanced for all new Boxster and Cayman models and for both engine versions:

- Modified transmission housing with new flange shape
- Modified 5th gear transmission ratio
- Drive-Off Assistant

With the new generation of engines, the flange shape between the engine and transmission has been redefined. The transmission housing has been reworked accordingly and the ribbed structure for improved stiffness on the inner wall of the transmission housing has been reinforced to withstand a higher load. The transmission ratio of the 5th gear has been modified to adapt to the higher power output and torque values of the new generation of engines and to harmonize the acceleration processes.

On the S models, the following features have also been reworked to take account of the higher power output and torque values as well as performance:

- Transmission ratio of pinion gear/ring gear and 6th gear
- Pinion gear/ring gear reinforced

These modifications also cause the transmission designations to change. The transmission type for the S version is now G87/40, while the designation G87/10 is used for the basic models.

Limited-slip differential

A mechanical rear differential lock with asymmetrical split is being offered as an option for the first time on the new Boxster and Cayman models with 18 and 19-inch wheels. The locking values are 22% for traction and 27% for deceleration.





4 Chassis

Boxster
Boxster S
Cayman
Cayman S

General information

The chassis concept of the new Boxster and Cayman models is the same as that of the previous models. The interaction of the individual components has been adapted on the new models to the increased performance of the new Boxster, Cayman and in particular their S versions in the following areas:

- Lightweight chassis with long wheelbase and large track widths with modified anti-roll bars and spring/damper units, specific setups for Boxster and Cayman respectively
- Adaptation of the driving dynamics to the new Porsche Doppelkupplung (PDK) for outstanding performance
- Highly responsive and agile hydraulic rack-and-pinion steering with variable ratio
- Sporty vehicle stability system PSM with the new brake system pre-filling and brake assist functions
- 4-piston aluminum monobloc fixed caliper brake system with internally vented and cross-drilled brake discs; the Boxster and Cayman are now also equipped with the S brake system on the front axle due to the increased performance. Optional Porsche Ceramic Composite Brake high-performance brake system for Boxster S and Cayman S
- New, open-style standard wheels for all models for optimum brake cooling
- Use of a new tire generation with reduced tire pressure on the rear axle for greater comfort with increased driving dynamics

Chassis

4



4_16_09

General information	107
Front axle	108
Rear axle	110
Porsche Active Suspension Management	111
Wheels and tires	112
Tire Pressure Monitoring (2nd generation)	114
Brake system	119
Porsche Stability Management (PSM)	120

In addition to the basic chassis, the variable damping system Porsche Active Suspension Management (PASM) with chassis lowered by 10 mm is offered for the Boxster/Cayman and Boxster S/Cayman S.

With the mechanical rear differential lock option, appropriately adapted anti-roll bars are installed at the rear axle.



4_17_09

Front axle

As before, the front axle consists of a strut suspension with trailing link and wishbone. To adapt to the improved performance of the new Boxster and Cayman models, the tuning of the standard components has been completely revised. Particular emphasis has been placed on realizing the higher performance while further improving comfort.

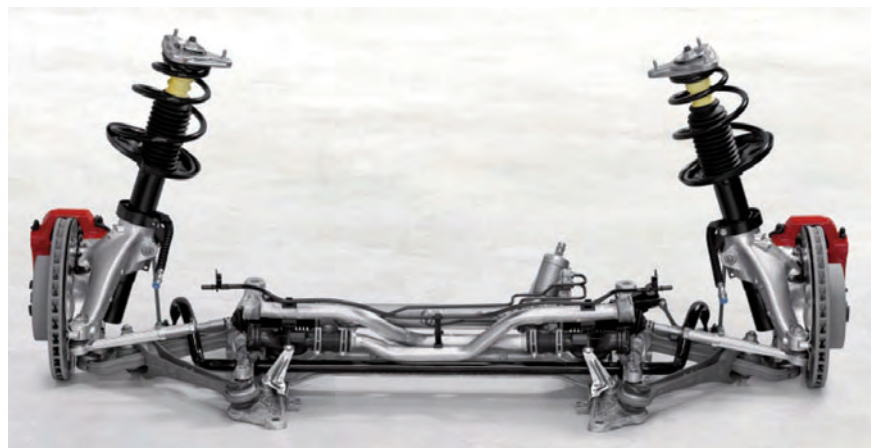

4_29_09

Spring strut

The spring strut consists of a double-tube gas-filled shock absorber and a coil spring, which in turn is adapted to the different vehicle versions.

The springs are color-coded to indicate the spring tolerance and the chassis version.

Anti-roll bars

The diameter and thickness of the anti-roll bars have been designed to match the vehicle's weight and driving dynamics. The following versions are installed:

	Boxster	Boxster S
Basis chassis	Tube 24.0 x 3.8 mm	Tube 24.0 x 3.8 mm
PASM chassis	Tube 24.5 x 3.8 mm	Tube 24.5 x 3.8 mm

	Cayman	Cayman S
PASM chassis	Tube 24.5 x 3.8 mm	Tube 24.5 x 3.8 mm
PASM sport chassis	Tube 24.5 x 3.8 mm	Tube 24.5 x 3.8 mm

Steering

The steering system has also been adopted from the previous models. With the variable steering ratio, the new Boxster and Cayman models also feature a steering system that offers excellent steering precision and agility, particularly on routes with many bends, as well as excellent driving stability at high speeds.



This technical data is intended merely as an overview. As it is subject to change in the course of the model year, the data published in the PIWIS information system always takes precedence. The allocation of colour codes is contained in the Parts Catalogue and/or in the PIWIS information system.



A modified steering gear with enhanced power assistance will be introduced during the course of the model year to reduce the steering effort. Basic information on the steering system can be found in the Technical Service Information for the Boxster (2005).



4_18_09



This technical data is intended merely as an overview. As it is subject to change in the course of the model year, the data published in the PIWIS information system always takes precedence. The allocation of colour codes is contained in the Parts Catalog and/or in the PIWIS information system.

Rear axle

The McPherson axle used on the new Boxster and Cayman is essentially the same as the axle used on the previous model. The springs, dampers and anti-roll bars have been redesigned for the new models. For driving comfort, new rebound stop springs have been used in the shock absorbers, while new foam pads have been used on the springs. All this fine-tuning has further enhanced the combination of driving enjoyment and practicality, offering maximum driving safety and comfort in conjunction with outstanding dynamic performance.

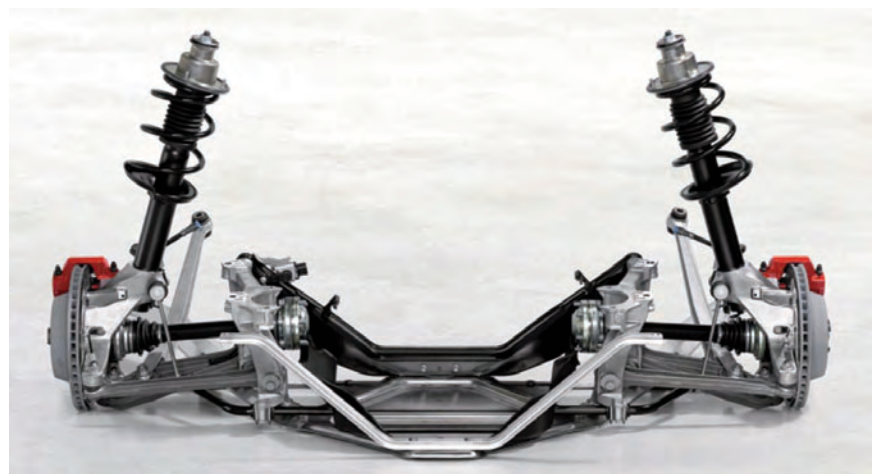

4_30_09

Spring strut

The spring strut consists of a double-tube gas-filled shock absorber and a coil spring, which in turn is adapted to the different vehicle versions. The springs are color-coded to indicate the spring tolerance and the chassis version.

Boxster, Boxster S

Basis chassis	Manual transmission	Spring rate: 33 N/mm
	PDK transmission	Spring rate: 37 N/mm
PASM chassis	Manual transmission	Spring rate: 40 N/mm
	PDK transmission	Spring rate: 43 N/mm

Cayman, Cayman S

Basis chassis	Manual transmission	Spring rate: 46 N/mm
	PDK transmission	Spring rate: 46 N/mm
PASM chassis	Manual transmission	Spring rate: 46 N/mm
	PDK transmission	Spring rate: 46 N/mm



Anti-roll bars

The diameter and thickness of the anti-roll bars have been designed to match the vehicle's weight and driving dynamics. The following versions are installed:

		Boxster	Boxster S
Basis chassis	Manual transm.	Tube 19.0 x 2.7 mm	Tube 19.6 x 2.6 mm
	PDK transmission	Tube 18.5 x 2.5 mm	Tube 19.0 x 2.7 mm
PASM chassis	Manual transm.	Tube 19.6 x 2.6 mm	Tube 19.6 x 2.6 mm
	PDK transmission	Tube 19.6 x 2.6 mm	Tube 19.6 x 2.6 mm
with rear-dif. lock	Manual transm.	Tube 19.0 x 2.7 mm	Tube 19.6 x 2.6 mm
	PDK transmission	Tube 18.5 x 2.5 mm	Tube 19.0 x 2.7 mm

		Cayman	Cayman S
Basis chassis	Manual transm.	Tube 18.5 x 2.5 mm	Tube 19.0 x 2.7 mm
	PDK transmission	Tube 17.2 x 2.5 mm	Tube 19.0 x 2.7 mm
PASM chassis	Manual transm.	Tube 18.5 x 2.5 mm	Tube 19.0 x 2.7 mm
	PDK transmission	Tube 17.2 x 2.5 mm	Tube 18.5 x 2.5 mm
with rear-dif. lock	Manual transm.	Tube 19.0 x 2.7 mm	Tube 19.6 x 2.6 mm
	PDK transm.	Tube 18.5 x 2.5 mm	Tube 19.0 x 2.7 mm

Porsche Active Suspension Management (PASM)

As on the previous models, the new Boxster and Cayman models also feature the electronically controlled damping system Porsche Active Suspension Management (PASM) with actively adjustable dampers.

To adapt to the improved driving performance of the new models, the system has been modified both hydraulically in its damping characteristics and with regard to system control. Each individual model has received due consideration in tuning the system.

PASM also combines two types of chassis in one on the new models. A comfortable sporty chassis in its basic setting and an sporty one at the touch of a button in the center console (PASM damper icon). PASM thus offers not only two rigid chassis setups, but even within the basic setup, variable damping adjustment is also available for each individual wheel.

Basic information on PASM can be found in the Technical Service Information for the Boxster (2005).



4_23_09



4_25_09



4_24_09



4_26_09

Wheels and tires

Standard wheels

All new Boxster and Cayman models come with newly developed 17 and 18-inch standard wheels in a unique design. Development work here focused on improving performance through lightweight materials and the actual design.

17-inch Boxster III wheel

The new Boxster, like its predecessor, comes with 17-inch wheels as standard. The design (17-inch Boxster III wheel) and the widening of the wheel rims at the front and rear axle are new. The wheel rims have been widened from 6.5J x 17 to 7J x 17 at the front and from 8J x 17 to 8.5J x 17 at the rear. The wider wheel rims at the front axle provide space for the larger brake discs. A further effect of the wider wheel rims is improvement of the driving dynamics. The tire dimensions remain unchanged at the front axle at 205/55 ZR 17 and are 235/50 ZR 17 at the rear axle.

18-inch Boxster S II wheel

The new Boxster S, like its predecessor, comes with 18-inch wheels as standard. These wheels have a new design (18-inch Boxster S II wheel) and the same dimensions at the front and rear axle. The dimensions at the front are 8J x 18 with 235/40 ZR 18 tires and 9J x 18 at the rear with 265/40 ZR 18 tires.

17-inch Cayman II wheel

The new Cayman, like its predecessor, comes with 17-inch wheels as standard. The design (17-inch Cayman II wheel) and the widening of the wheel rims at the front and rear axle as on the Boxster are new. The wheel rims have been widened from 6.5J x 17 to 7J x 17 at the front and from 8J x 17 to 8.5J x 17 at the rear. Similar to the Boxster, the wider wheel rims provide space for the larger brake discs and increase the traction and driving performance. The tire dimensions remain unchanged at the front axle at 205/55 ZR 17 and are 235/50 ZR 17 at the rear axle.

18-inch Cayman S II wheel

The new Cayman S, like its predecessor, comes with 18-inch wheels as standard. These wheels have a new design (18-inch Cayman S II wheel) and the same dimensions at the front and rear axle. The dimensions at the front are 8J x 18 with 235/40 ZR 18 tires and 9J x 18 at the rear with 265/40 ZR 18 tires.

Tires

To guarantee the improved driving performance of the new Boxster and Cayman models, the tires have also been enhanced. Improved rubber compounds and redesigned tires ensure higher performance. Low rolling resistances were also taken into consideration during the development of the new tires.

In addition, the tire pressures at the rear axle have been reduced compared to the previous models. This reduction amounts to 0.4 bar for the 17 and 18-inch wheels and 0.2 bar for the 19-inch wheels. These measures improve driving comfort, in particular, providing for high performance potential without changing the rolling resistance. To ensure the reliable allocation of tires to the corresponding vehicle versions, the tested and approved tires have been provided with the familiar N specification.

Run-flat systems

Like the previous models, the new Boxster and Cayman models come as standard with a space-saving tire repair system comprising tire sealing compound and an electric pneumatic compressor.

Tire Pressure Monitoring (2nd generation)

Timely detection of a gradual loss of pressure not only increases driving safety, but can also prevent uneven tire wear and increased fuel consumption. The optional Tire Pressure Monitoring system (TPM) has therefore been available for all Boxster and Cayman models since the end of 2005. It continually monitors the air pressure in all four tires and displays this information for the driver in the instrument cluster.

A new generation of TPM system is used on the new models. As on the previous models, this system (standard equipment in USA) continuously monitors the air pressure of each tire. The advantage of the new TPM generation is that the tire pressure values are transmitted and displayed much faster in the instrument cluster once the ignition is switched on and after changing a wheel.

Apart from affording greater protection in the event of tyre damage, the new TPM system primarily gives drivers advance warning about excessively low pressure as a result of natural diffusion as well as gradual loss of pressure in individual tires by continuously monitoring the tire pressure. Essentially, only the correct tire pressure ensures safe driving and high driving dynamics. The most important additional function in the system is the option for automatically and quickly detecting the wheels installed on the vehicle (own wheels) and their installation position.

The radio messages from the wheel electronics units are requested by the control unit as required via the trigger transmitters. The system detects the vehicle's own wheels and the installation position of the wheels by evaluating the trigger location and performing a statistical evaluation of the information received from the wheel electronics units.

Design and function

Control unit

Similar to previous models, the control unit is located at the front of the luggage compartment on the right-hand side. The control unit analyses the incoming data from the antenna and forwards the relevant information to the instrument cluster. Since the data is transmitted via cable from the central antenna, the control unit is designed to pick up both frequencies (433/315 MHz). If a new control unit is installed, it must be coded accordingly.

Triggers (trigger transmitters)

The four triggers, which are located under the wheel housing liners in each of the four wheel housings, send a 125 kHz signal directly to the wheel electronics units in order to transmit the desired information to a central antenna immediately.

When the vehicle is unlocked, the control unit initiates the first 125 kHz signal for each trigger in the four wheel housings one after the other, starting at the front left and proceeding in clockwise direction. Then, the wheel electronics units are only triggered approx. every 60 seconds while the vehicle is moving. Since the range of the trigger signals is limited to the relevant wheel housing, any possibility of cross-talk affecting other wheels is almost totally eliminated. Depending on many and varied influences from the immediate environment, such as reflections (wet roads, metallic floors, guide rails, etc), external interference (external transmitters), as well as bad positioning of the wheel electronics units with respect to the trigger and/or central antenna, a trigger signal can fail to reach the related wheel sensor or the feedback data protocol can get lost on its way to the central antenna. The control unit responds immediately by re-triggering the trigger – repeatedly if necessary – at the wheel position at which the expected protocol has failed to materialise as soon as the initiated trigger cycle from front left to rear right is completed. This concept reduces system interference and the wheel electronics units are detected much faster.

Central antenna

The digital central antenna (reception frequency 315 or 433 MHz) is secured to the vehicle floor in the center tunnel between the water tubes. The signals received from the wheel electronics units are digitized in the antenna and forwarded to the control unit via two lines (LIN bus). The digital antenna has an integrated self-diagnosis facility. This means that when a fault is detected, it is stored in the control unit fault memory and displayed on the PIWIS Tester.

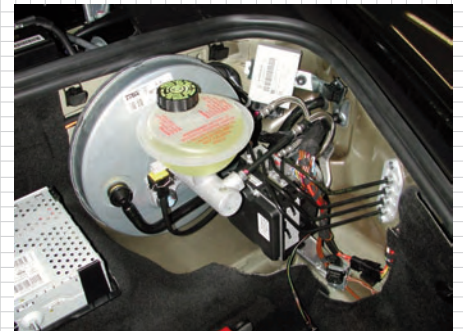

4_27_09



4_11_09



4_10_09



4_13_09



The learning phase generally takes about 20 - 60 seconds, but can last up to 3 minutes (net driving time) in certain situations.

Wheel electronics

The wheel electronics unit (wheel transmitter, 433 or 315 MHz) is screwed to the rim using the wheel valve.

The wheel electronics unit comprises the following components:

Pressure sensor, temperature sensor, roll switch, measuring and control electronics, receiver and transmitter as well as a battery.

The wheel electronics unit can be triggered and receives send requests from the TPM control unit via four trigger senders. This means that the antenna always receives only one data protocol and this comes from the wheel electronics unit that received the request to send. This gives the system added protection against cross-talk affecting other antennas. Higher transmission power is used due to the longer radio link to the central antenna. The roll switch detects whether the wheel is stationary or turning.

This information is used either to start a triggered learning process for a moving wheel or to switch off the wheel electronics unit when the wheel has been stationary for a long time.

To avoid confusion with 1st generation wheel electronics, the new wheel electronics unit can be identified by the modified shape of the housing, the small air filter and the part number stamped on it. A modified data protocol ensures that the wheel electronics unit will not be detected if installed incorrectly and corresponding units are stored as defective in the fault memory.

The following aspects of the system have been optimized by changing the system hardware and software:

Fast learning following a wheel change

The wheels of a newly mounted set of wheels are re-taught after a new set of wheels is selected in the "Tire pressure" menu. The learning process is only active while the vehicle is moving. After the vehicle has been driven for about 20 to 60 seconds, the system has learned and identified the positions of its own wheels. The TPM warning light then goes out and the message "TPM is learning, monitoring not act." disappears.

During the learning phase, lines appear at the wheel positions on the on-board computer. The required pressure for the front and rear axle is displayed in the "Pressure info" menu.

Fast detection of a wheel change without re-calibration

If the TPM system is not re-calibrated following a wheel change, the system detects this within max. 3 minutes of driving the vehicle and generates the message “Wheel change? Input new TPM settings” in order to ensure that the correct nominal pressure is configured for the monitoring process by selecting the correct tires.

Immediate pressure display at the start of a trip

With the Pre-Drive Check (fast sequence of triggers), which starts when the door closes, the current tire pressure can generally be displayed in the instrument cluster approx. 5 seconds after switching on the ignition.

Fast pressure update following tire pressure adjustment

The differential pressure display appears as filling information in the “Tire pressure” menu when the vehicle is stationary in order to ensure that the tires are filled correctly. As soon as this information is called up, a fast pressure update is generated over a time span of max. 15 minutes and this update information shows the current tire pressure every 10 seconds during tire pressure adjustment.

Partial monitoring

With the new TPM generation, if one wheel electronics unit fails, the system continues to monitor the pressure in the other wheels, thereby ensuring that the pressure in the other wheels is still displayed. Only lines (–.–) are displayed for the defective wheel position in the instrument cluster.



USA vehicles only

For USA-coded TPM, the TPM warning light flashes in the following situations:

- System is not active
- System is not active – brief disturbance
- System is not active, system is learning
- Wheel change, new TPM settings are entered
- TPM display is defective (control unit is disconnected from the wiring harness)

The TPM light flashes for between 60 and 90 seconds and then stays on continuously until the TPM system is active again. When the ignition is switched on or off, the TPM light starts flashing again if the previous system status remains unchanged.

Soft warning

The main purpose of the soft warning is the early detection of pressure loss over time as a result of diffusion. This warning can only be generated up to a speed of max. 100 mph (160 km/h). If the tire pressure is 4 to 7 psi (0.3 to 0.5 bar) too low (previous models: 3 to 6 psi (0.2 to 0.4 bar), "soft warning" first appears in white text only when the vehicle is stationary and remains displayed for approx. 10 seconds after switching off the ignition. This warning then appears again each time the ignition is switched on or off until the tire pressure in the affected wheel is inflated again to the required pressure. The warning in the display can be acknowledged so as to free up the on-board computer for displaying other information. However, the TPM warning light, which comes on at the same time, remains active.

Driving safety is assured provided the tyre pressure is corrected during the next service station stop. The crucial reading is the differential pressure values, standardised to 68° F. (20° C), which are displayed in the "Pressure Info" menu. Tire inflation devices can be inaccurate and can show the uncompensated tire pressure. The message disappears as soon as the tyre pressure is correct again.

Hard warning (puncture)

A "hard" warning appears in red if:

- the tire pressure is more than 7 psi (0.5 bar) too low for the speed range from 0-100 mph (0-160 km/h)
- the tire pressure is more than 6 psi (0.4 bar) too low for speeds of over 100 mph (160 km/h)
- the pressure is falling faster than 3 psi (0.2 bar) per minute

This warning appears as soon as the respective values are exceeded, regardless of whether the vehicle is stationary or moving. Driving safety is no longer guaranteed. This message can be acknowledged, but the TPM warning light, which comes on at the same time, remains active. The message is displayed again whenever the ignition is switched on and off. It only disappears when the tire pressure is correct again.

Brake system

To meet the high requirements with regard to the braking performance of a Porsche, all new Boxster and Cayman models also have a brake system that is optimally designed to suit the relevant vehicle features. The standard brake system of the Boxster and Cayman models with a 2.9-liter engine features black anodized brake calipers, while the standard brake system of the respective S models with a 3.4-liter engine features brake calipers with a red paint finish and the optional ceramic brake system Porsche Ceramic Composite Brake (PCCB) has yellow brake calipers.

Standard brake system – Boxster and Cayman

The front axle on the new basic Boxster and Cayman vehicles has been fitted with the same brake system as the S versions. As a result, the cross-drilled and involute-shaped internally vented brake discs at the front axle have increased in size from 298 x 24 mm to 318 x 28 mm. The proven cross-drilled and internally vented brake discs with the dimensions 299 x 20 mm are used at the rear axle.

Standard brake system - Boxster S and Cayman S

The new S models come with the high-performance brake system used on the previous models with cross-drilled and internally vented brake discs. Discs with the dimensions 318 x 28 mm are fitted at the front axle. Increased braking performance compared to the basic models is required at the rear axle due to the greater engine power. The brake discs are therefore 4 mm thicker than on the basic vehicles at 299 x 24 mm.

Porsche Ceramic Composite Brake (PCCB)

The new Boxster S and Cayman S models are also optionally available with the Porsche Ceramic Composite Brake (PCCB). The dimensions have been adopted from the previous models.

Brake booster

The ratio of the brake booster on the Boxster/Boxster S and Cayman/Cayman S models with the standard brake (grey cast-iron brake discs) has been increased to $i=5$. If the Boxster S/Cayman S is fitted with PCCB, the ratio is still $i=4.5$.



4_21_09



4_28_09



4_22_09

Porsche Stability Management (PSM)

Like the previous models, the new Boxster and Cayman models come as standard with Porsche Stability Management for high active driving safety in manoeuvres involving extreme longitudinal and lateral acceleration without affecting the typical Porsche agility.

It comprises the following features:

Longitudinal dynamics control

- ABS 4-channel anti-blocking system
- ABD Automatic brake differential
- ASR Anti-slip regulation
- MSR Engine drag torque control
- EBD Electronic brake-force distribution

Lateral dynamics control

- FDR Driving dynamics control (wheel-specific braking intervention)

Enhanced longitudinal dynamics control

Enhanced longitudinal dynamics control is a new feature for rear-wheel-drive models. It improves braking functions and active safety, in particular, by reducing stopping distances via the following additional functions:

- Improved braking readiness through pre-filling of the brake system
- Brake assist
- Drive-Off Assistant

Enhanced braking readiness

The enhanced braking readiness through pre-filling of the brake system serves to shorten the stopping distance in emergencies. When the accelerator pedal is released very quickly (an action that typically indicates imminent emergency braking), brake fluid is pumped from the PSM hydraulic unit to the wheel brakes before the brake pedal is actually pressed. As a result, the brake pads are gently applied to the brake discs, preparing the brake system for the impending braking operation. This significantly reduces the deceleration build-up when the brake pedal is subsequently pressed, thereby substantially improving the brake system's response and shortening the stopping distance.

Brake assist

The brake assist facility also reduces the stopping distance. In addition to vacuum-controlled brake boosting via the brake booster, additional hydraulic brake boosting also takes effect in response to full braking. On identifying full braking, i.e. when a defined actuating speed and force is exceeded on the brake pedal, the PSM hydraulic unit actively supplies the required brake pressure for maximum deceleration.

For improved sporty driving, brake assist and thus the additional brake booster function is deactivated when PSM is switched off (PSM OFF) or when the Sport button is pressed in the optional Sport Chrono Package Plus.

Drive-Off Assistant

All new Boxster and Cayman models both with manual transmission and with the new Porsche Doppelkupplung (PDK) feature a Drive-Off Assistant as standard. It prevents the vehicle from rolling forward or back on a hill for a limited time by holding the vehicle automatically and in a controlled way using the operating brake. The Drive-Off Assistant allows the driver to move off comfortably and smoothly on a hill without applying the handbrake.

Essentially, the entire Drive-Off Assistant function depends on the position of the vehicle on the hill and the desired direction of travel as well as the selected gear. The Drive-Off Assistant is active if the vehicle is facing uphill with a forward gear engaged. The function is deactivated when you put the vehicle into reverse gear in order to park the vehicle for example. The Drive-Off Assistant is only active in reverse gear if the vehicle is facing downhill.

As soon as the vehicle comes to a stop on a hill by specifically using the brakes, the hydraulic brake pressure selected by the driver prevents it from rolling forward or back. The vehicle is held for as long as the driver keeps the brake pedal pressed. When the brake pedal is released, the PSM hydraulic unit slowly reduces the brake pressure after a maximum time of approx. 2 seconds, thus disabling the automatic hold function. The brake pressure is also reduced when moving off on a hill if the driver accelerates (on vehicles with Porsche Doppelkupplung (PDK)) or accelerates and releases the clutch (on vehicles with manual transmission) immediately after releasing the brake pedal, thereby building up sufficient drive torque.





S VM 2507

5 Body

Boxster
Boxster S
Cayman
Cayman S

General information

The Boxster models for model year 2009 are a clear enhancement of the unique Boxster design.



Body



5_01_09

Boxster, Boxster S	
General information	125
Bodyshell	126
Cayman, Cayman S	
General information	127
Bodyshell	128

Boxster
Boxster S
Cayman
Cayman S

Body

5

Bodyshell

The bodyshell technology is essentially the same as for model year 2005 with regard to bending and torsional rigidity as well as side impact protection and is described in the Technical Service Information brochures for the Boxster and Boxster S, model year 2005.

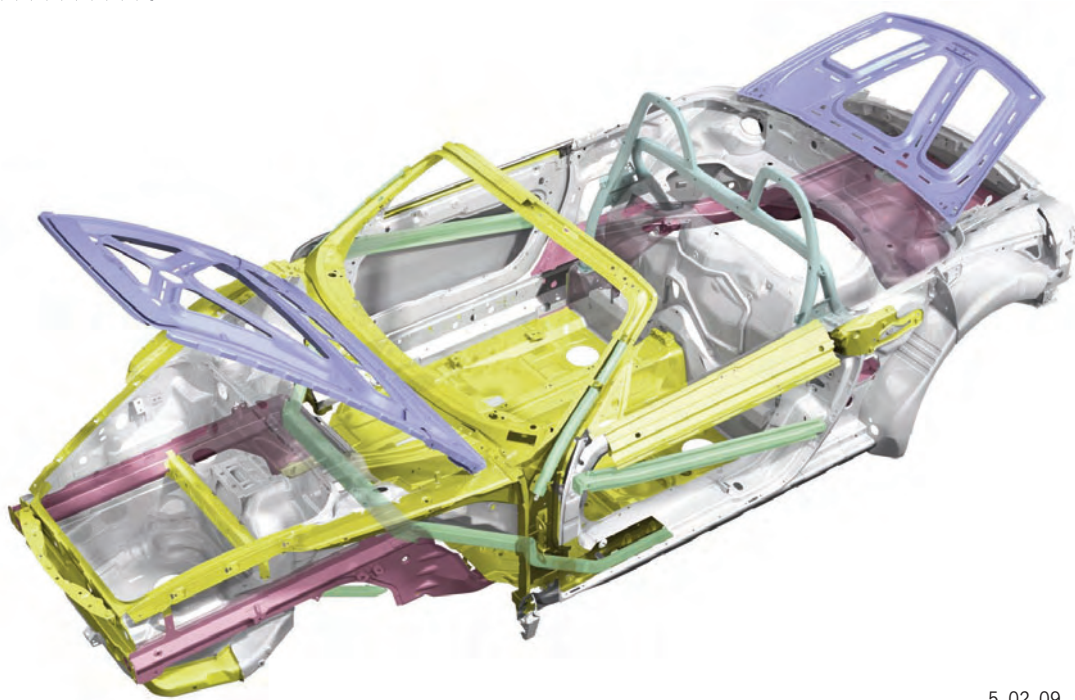

5_02_09

- Sheet steel
- Tailored blanks
- High-strength steel
- Ultra-high-strength steel
- High-strength austenitic stainless steel
- Aluminum

General information

The design of the Cayman models is characterized by a particularly muscular dynamism. At the same time, the elongated coupé line produces a visual impression of elegance and very high quality.



5_04_09

Boxster
Boxster S
Cayman
Cayman S

Body

5

Bodyshell

The bodyshell technology is essentially the same as for model year 2006 with regard to bending and torsional rigidity as well as side impact protection and is described in the Technical Service Information brochures for the Cayman and Cayman S, model year 2006.

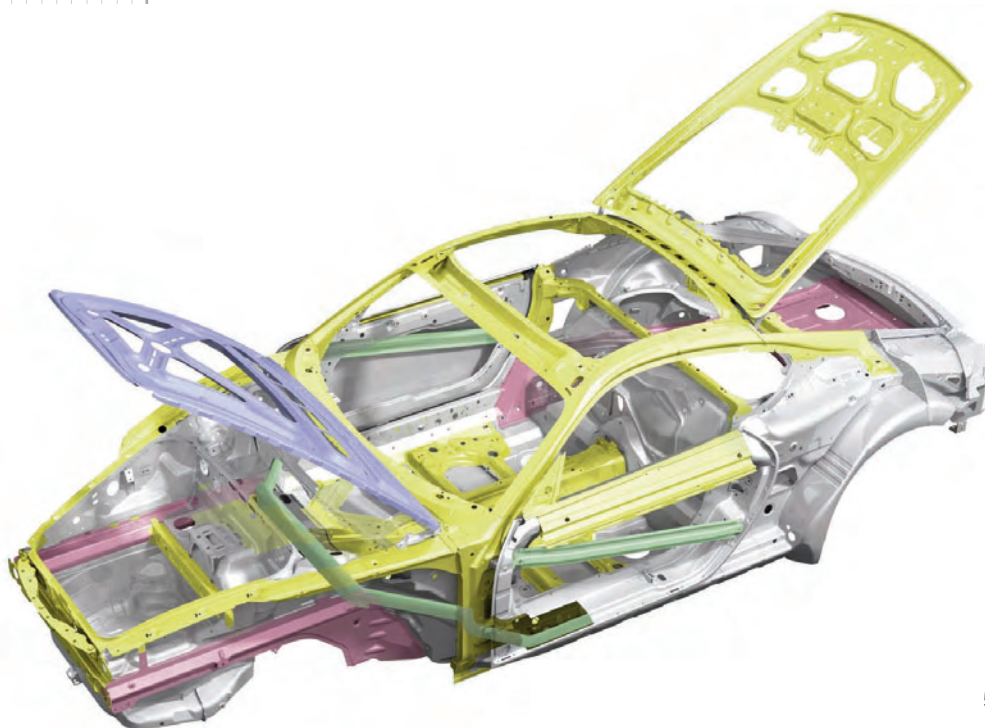

5_05_09

- Sheet steel
- Tailored blanks
- High-strength steel
- Ultra-high-strength steel
- Aluminum

6 Exterior body equipment

General information

The main objective of the Porsche designers for the new Boxster models was to make the classic design of the Boxster even more sporty and more dynamic, while at the same time ensuring greater visual differentiation between the Boxster and the Cayman – in terms of both the day and night design.

As always, the motto “form follows function” applied here too. Design and functionality are in harmony on the new Boxster models also. The increased cooling air requirement of the more powerful engines has been taken into consideration, as has the stipulation for further optimization of the aerodynamics.

Key features of the new Boxster design are:

- New front and rear aprons
- New and larger external air intakes with bars in the exterior color on the Boxster and contrasting Black bars on the Boxster S
- Main headlights essentially with 2-tube look; additionally emphasized by the double-lens projection system of the optional Bi-Xenon headlights with dynamic cornering light
- Use of LED technology: standard for LED position light and LED tail lights, optional as LED daytime running lights in the package with the Bi-Xenon headlights
- Diffusor inserts in the rear section and new striking tailpipes
- Restyled standard wheels and door mirrors for all models



Exterior body equipment

Boxster, Boxster S	
Exterior body equipment	129
Cayman, Cayman S	
Exterior body equipment	135

Front view

In the front view it is clear that the lines are much more angular compared to the previous model, with a greater emphasis on diagonal lines. The result is a modern, more dynamic face for the vehicle. The headlights essentially have a 2-tube look and are reminiscent of the legendary Carrera GT. On the optional Bi-Xenon headlights with dynamic cornering light, this look is additionally emphasized by the double-lens projection system.

The redesigned air intakes are bigger than before in consideration of the increased cooling air requirement of the more powerful engines and together with the more accentuated front spoiler edge visualise the high performance of the new Boxster models.

The Boxster has been upgraded and for the first time features a middle air intake opening like the Boxster S.

Two cross bars integrated in the external air intakes are in the exterior color on the Boxster.

On the Boxster S, they are in contrasting Black to lend greater emphasis to the large air intakes.



6_01_09

Side view

The new front air intakes are also visible in the side view and, together with the strongly emphasized front spoiler that continues around to the side, consolidate the very sporty appearance. The classic Boxster line with short projections and central driver position is reinforced.



6_02_09

Door mirrors

The shape of the double-arm door mirrors has been redesigned in order to increase the field of vision to the rear and comply with future legal requirements. Optimized water management also means that the mirror glass stays much cleaner.



6_03_09

Rear view

The new Boxster models feature a completely new rear apron. The lower line of the new tail lights with their more delicate appearance overall exhibits a downward curve: this shifts the visual focus downwards while also emphasizing the muscular width of the rear. The curve of the lower line breaks up the former formal severity of the rear, as on the new 911. The tail lights taper outwards to a point, adding a sharp touch to both the rear and side views.



6_04_09

The new diffuser inserts arranged to the left and right of the likewise redesigned central tailpipes ensure a very powerful and striking rear view. This places greater emphasis on both the sporty, wide track and the area of the tailpipes. On the Boxster, the central individual tailpipe has been given a new, very high-quality design. On the Boxster S, a likewise redesigned twin tailpipe coming directly from the intermediate pipe of the exhaust system ensures a very sporty look reminiscent of the last 911 GT3 and acoustics which convey power and confidence in impressive guise.



6_05_09

Convertible top

The Boxster is a classic roadster. It therefore has a very closely cut, lightweight fabric top, which stows away under its cover by electric means in just 12 seconds and does not impact the available load options even when stowed. The top made from magnesium, fabric and a little glass is lightweight and needs very little storage space. A folding roof made of steel, for example, has disadvantages with respect to weight, weight distribution and luggage compartment capacity.



6_06_09

The Z-shaped fold of the Boxster's top protects the inner surface and requires little space for storage. The top can also be opened or closed when driving at speeds up to 50 km/h (30 mph) and is suitable for use all year round, providing for very pleasant climatic conditions and low noise.

Boxster
Boxster S
Cayman
Cayman S

Exterior body equipment

6

Occupant protection

The Boxster and Boxster S come with full-size airbags for driver and passenger as standard.



6_07_09

General information

The main objective with the new generation of Cayman models was to enhance both the powerful dynamism and the uniqueness of the design.

The changes to features are similar to those made on the Boxster models (new front and rear apron, new and larger external air intakes with redesigned front light modules, new LED lighting concept, redesigned standard wheels and door mirrors, new tailpipes).

Unique key features of the new Cayman design are:

- Identical front section for Cayman and Cayman S with an even more striking look
- Separate LED daytime running lights in the front light modules (optional in the package with Bi-Xenon)
- New and unique standard wheels
- Restyled rear number plate cut-out and tail unit

Front view

More heavily accentuated on the new Cayman models than on the Boxster are the strong diagonal lines that describe a downward-pointing “V” from the joints of the luggage compartment lid through the headlights to the middle air intake and give the face of the vehicle a more athletic look. The more angular lines create a new modernity.

The standard round fog lights in the separate front light modules have been moved further towards the outside, thereby reinforcing the sporty, wide look. Horizontal LED position lights are now located on the inside of the fog lights for a distinctive night design.

The redesigned external air intakes take up the shape of the new halogen headlights and appear much larger and more dominant than before, among other things through the omission of the previous horizontal bars in the exterior color.



6_08_09

Side view

The Cayman is characterized in particular by a striking side view:

- Strongly curved quarter panel
- Emphasized sculpting
- Long wheelbase with short projections
- Long, flowing line from the roof to the rear typical of the coupé
- No B-pillar
- Sharply contoured side skirts that visually simulate the flow of air to the side air intakes
- This dynamic upwards curve is taken up by the rear section of the side windows

The new front section also visible in the side view as well as the outwardly tapered tail lights add new highlights.



6_09_09

Door mirrors

The shape of the double-arm door mirrors has been redesigned in order to increase the field of vision to the rear and comply with future legal requirements. Optimized water management also means that the mirror glass stays much cleaner.

Rear view

The rear section exudes a strong appeal. This comes from two side lines that form the boundary of the roof and continue down over the large rear lid to the completely redesigned rear apron of the new Cayman. This gives the rear view an even more athletic look.



6_10_09

The redesigned number plate cut-out as well as the redesigned tail unit in the lower part of the rear apron emphasize the width and give the vehicle the appearance of making “fuller” contact with the road.



6_11_09

The new tail lights are identical to those on the Boxster models. They shift the visual focus downwards and also emphasize the muscular width of the rear. Especially on the Cayman, the outer downward curve of the lights also emphasizes the strongly contoured muscular quarter panels.



6_12_09

Boxster
Boxster S
Cayman
Cayman S

Exterior body equipment

6

Occupant protection

The Cayman and Cayman S come with full-size airbags for driver and passenger as standard.



6_13_09

7 Interior body equipment

General information

The interior of the new Boxster and Cayman models has been revised with respect to ergonomics and design quality. On the new models it is now much tidier and of better quality with a new center console. The integrated new CDR-30 radio together with the operation of the air conditioning has been completely redesigned. The black frame emphasizes the sportily ergonomic appearance. A smaller number of large, clear operating buttons ensures greater clarity with further improved functionality.

Interior body equipment

7



7_01_09

General information	141
Steering wheel	142

Steering wheel

The steering wheel rim of the standard steering wheels used in the new models now has a high-quality smooth leather trim. The airbag module features a soft-touch painted finish. From this generation on, the vehicle equipment with the optional leather interior includes a leather airbag module as well as V-shaped decorative stitching on the upper part of the switch panel. This emphasizes the appearance of the middle air intakes and improves the look and feel of the leather interior.

The heated steering wheel available as an option in combination with Porsche Doppelkupplung (PDK) improves driving comfort in winter in particular. The heated steering wheel can be conveniently activated or deactivated separately by means of a switch in the 6 o'clock spoke of the Porsche Doppelkupplung (PDK) steering wheel.

The redesigned 3-spoke sports steering wheel for Porsche Doppelkupplung is always installed with the optional Porsche Doppelkupplung (PDK). The new, optional multi-function steering wheels for Porsche Doppelkupplung (PDK) have a very sporty design and can be finished in smooth leather, Macassar wood, carbon and Aluminium Look. All steering wheels for Porsche Doppelkupplung (PDK) have conveniently arranged sliding buttons for changing gear manually.





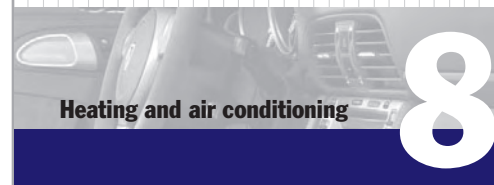

8 Heating and air conditioning

Externally controlled compressor

General information

The 2nd generation Boxster and Cayman models, like the 911 Carrera, are fitted with an “externally controlled compressor”.

With the externally controlled system, the air conditioner operating panel has a direct effect on the compressor and thus on the cooling output. Given this, most changes to this system relate to the compressor or compressor control. The components, which you will be familiar with from the air-conditioning system used on the previous model, are not modified to any great extent by this system and are essentially identical from the point of view of design and operating principle.

A comparable externally controlled compressor system is also used in the Cayenne.

Advantages of an externally controlled compressor:

- Reduced weight due to omission of a compressor clutch
 - Total weight reduction here: approx. 1.4 kg (approx. 3 lbs)
- No need to push the clutch when engaging (high-comfort use)
- Refrigerant output is controlled more precisely and is demand-controlled, based directly on the evaporator temperature

System parameters

- Externally controlled compressor (electronic control valve)
- No magnetic clutch (compressor runs continuously)
- System is controlled via evaporator temperature (similar to the Cayenne)
- Control valve is activated from the air conditioner operating panel (new software)
- Some refrigerant lines are rerouted due to modified engine (DFI engine)

Externally controlled compressor	145
Air-conditioned seats	151
Heated steering wheel	155



The air-conditioning compressor switches off automatically at outside temperatures of below approx. 35° F. (2° C) and cannot be switched on again – even manually – by pressing the “Auto” button.

The pressure relief valve opens at a critical system pressure of 40 ± 4 bar to protect the lines from irreparable damage. The valve closes again when pressure compensation is complete. The valve is located directly on the compressor, on the high-pressure side.

Operating principle of the externally controlled compressor

The externally controlled compressor (from Denso) is an air side-controlled swash-plate (adjusting) compressor, similar in function and design to the compressors used on the previous models. The gaseous refrigerant has a pressure of 145 - 435 psi (10 - 30 bar) and a temperature of up to 212° F. (100° C) when it exits the compressor at maximum delivery rate. The compressor always runs when the engine is running and is not just switched on via a clutch relay.



8_01_09

An electronic control valve – integrated into the back of the compressor – also allows the high pressure of the refrigerant circuit of approx. 145 - 435 psi (10 - 30 bar) into the crank chamber housing if necessary (a by-pass bore opens).

As with all similar compressors, the crank chamber is connected to the low-pressure side of the refrigerant circuit via another bore for the return flow (pressure compensation between the high and low-pressure side via the return bore). As a result, the angle of attack of the swash plate can be reduced (towards zero delivery) without any great force by a spring working on the plate.

The control valve is controlled by a variable PWM signal from the air conditioning control unit (operating panel). The control unit uses the signal from an evaporator temperature sensor as the basis for controlling the control valve (for more information, see “Evaporator temperature sensor”). The basic frequency for the valve is 400 Hz.

Variable PWM signal (400 Hz)

Amperage rating [amp]	Compressor status
0.0 – 0.3	Off (no load)
0.3 – 0.8	Continuous adjustment
> 0.8	Limited

The piston stroke can be varied continuously via the change in the amperage rating of the PWM signal, as described above by means of pressure compensation in the crank chamber housing (opening a by-pass bore).

This type of control ensures a large stroke for a high (refrigerant) delivery rate and a small stroke for a lower delivery rate from the compressor. Since the compressor operates with a variable delivery rate, there is no need to control the cooling output of the air conditioning system by switching a compressor relay on and off. In other words: the compressor continues to run even when there is sufficient cooling output, but can operate with zero delivery (swash-plate deflection: approx. 3 degrees). In this case, the compressor is running without a load.



At a coolant temperature of $T > 244^{\circ}\text{F}$. (118°C), a forced suppression of the air conditioning system is requested of the air conditioning control unit by the DME system via the CAN bus. For this purpose, the electronic control valve sets the compressor to zero delivery mode (both radiator fans running).



A timed full-load shutdown (compressor function is disabled) occurs if the throttle position is greater than 92%.

Speed is taken into consideration here when setting the driver setpoint torque.



Information is provided via CAN in order to dim the displays in the LCD display.

Operation (air conditioner operating panel)

Air conditioning control is operated via an operating panel (air-conditioning regulator) with an integrated control unit in the centre console. The operating panel looks similar to the operating panel used in the current sports car except for small changes on the operator interface. These changes are not relevant for the externally controlled compressor.

The most important changes on the operator interface are as follows:

- AC OFF (ECO function = compressor runs in zero delivery mode)
- Integration of the two buttons for air-conditioned seats (see also system description for "Air-conditioned seats")
- Position of some operating buttons changed

Similar to the previous model, all heating functions in the vehicle are controlled via one unit.



8_02_09

Actuators and sensors

Evaporator temperature sensor

The temperature of the evaporator is primarily used as the basis for controlling the electronic control valve in the externally controlled compressor. The sensor is not fitted directly in the evaporator vanes. It is located at a parallel position approx. 20 mm behind the evaporator. At this distance from the evaporator, the sensor can measure a homogenous air-flow temperature for all temperature levels.

The evaporator is also prevented from freezing, based on this measured temperature. If there is a danger of freezing, the air conditioning operating panel reduces the angle of attack of the swash plate (pressure compensation between high and low-pressure side) by triggering the electronic control valve and therefore reduces the refrigerant delivery rate. There is now less refrigerant available for evaporation and this counteracts the possibility of freezing.



8_04_08

Position of the evaporator temperature sensor

On the sports car, the evaporator temperature sensor (arrow) is located on the back of the heater unit housing. The connecting cable for the sensor is routed close to the condensation outlet.

To remove this sensor, you must reach in between the bulkhead (passenger's side) and the rear wall of the housing. The sensor is released when it is turned a quarter-turn and can then be removed from the heater unit housing.

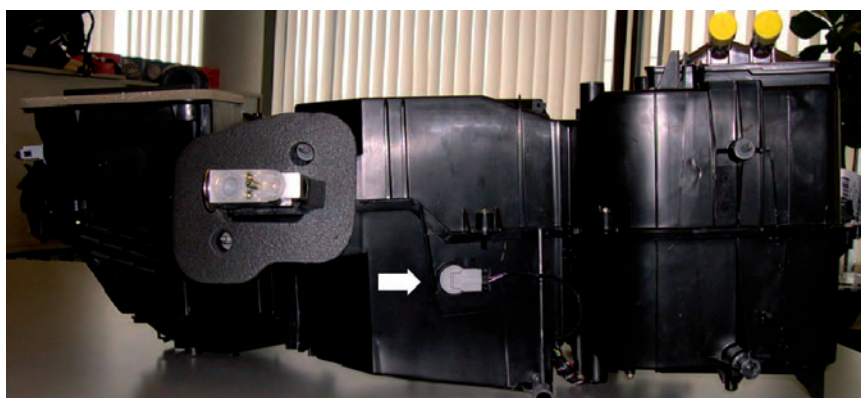

8_05_08

Air-conditioned seats

General information

Seat ventilation or ventilation for the two front seats (standard or fully electronic seats) is also available as an option in combination with heated seats for the 2nd generation of Boxster and Cayman models. Three comfort settings can be activated independently using buttons in the air conditioner operating panel. The fans integrated in the seat and in the backrest remove perspiration between the passenger and the surface of the seat. This ensures that passengers enjoy pleasant and dry seating comfort without draughts even in extreme heat.

Advantages of air-conditioned seats:

- Healthy and warm/dry air conditioning on the seat surface
- Improved passenger comfort by regulating the transport of heat/moisture
- Increased personal comfort
- Excellent seating comfort



8_06_09



A temperature sensor is integrated in the heating element in the seat surfaces of both seats.

A temperature of at least 59° F. (15° C) must be measured both by the temperature sensors in the seats and the interior temperature sensor (in the operating panel).

Seat airing and ventilation is not switched on or off if the temperature is less than 59° F. (15° C) in order to prevent excessive cooling.

Operating principle of air-conditioned seats

Fine perforations in the leather cover on the centre strip of the seat and backrest allow the surface ventilation or airing of the seat upholstery. The passengers' requirements with regard to seating comfort for the two front seats can be met individually by adjusting the ventilation and air-conditioning level and selecting the required seat heating setting.

Seat ventilation/airing can be switched on and off at the touch of a button on the air conditioner operating panel. The highest of the three comfort settings is activated first when you touch the button. The three LEDs in the switch show which fan setting is currently activated.

The seat surface is ventilated evenly by a fan controlled by the air conditioner operating panel and integrated in both the seat and backrest. The efficient and acoustically discrete fans draw off perspiration between the passenger and the surface of the seat through the perforated center strip in the seat and backrest. The intake air flows through an air-permeable cushioned mat, is transported off via special air ducts arranged in the seat and is directed into the interior of the vehicle. In this way, the seat surfaces heated by the sun cool down quickly and prevent perspiration.

Seat ventilation can be combined with temperature control for heated seats. This ensures the continuous removal of moisture while maintaining a pleasant seat-surface temperature.

Controlling air-conditioned seats

The fan modules in the seat surfaces and backrests are activated directly from the air conditioner operating panel. The PWM signal used for this has a frequency of 100 Hz. The three possible settings run at 100%, 78% and 68%. The fans are powered directly by the vehicle electrical system (terminal 15).

Seat ventilation and seat heating only work when the engine is running. The decision as to whether both systems (seat ventilation and seat heating) are activated depends on the air conditioner operating panel.

Components of air-conditioned seats

The system, which can be ordered as an option together with seat heating, comprises the following main components:

- 3-stage operating button in the air conditioner operating panel next to the operating button for seat heating for driver and passenger
- Fan modules for the seat surface (item 1) and backrest (item 2)
- Air ducts in the seat surface and backrest (see arrows for air routing)
- Air-permeable cushioned mats
- Main wiring harness (not described here)



8_07_09



The fans are no longer activated or switched off automatically by the air conditioner operating panel when the voltage is less than 9 volts and more than 16 volts.

The signal from the temperature sensor (sensor integrated in the seat-surface heating element) is used to regulate seat heating.



8_03_09

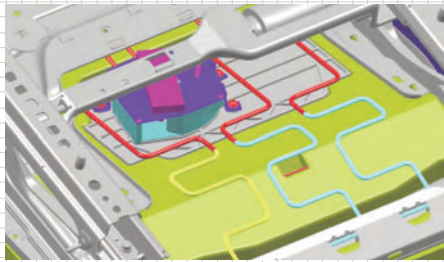

8_09_09

- 1 Fan module
- 2 Cushion foam
- 3 Air-permeable cushioned mat

- 4 Cushion foam structure (fixed in the middle)
- 5 Opening for fan module (seat surface)



8_11_09

- 6 Air-permeable cushioned mat
- 7 Heating element (integrated temperature sensor)
- 8 Cushion foam
- 9 Fan module carrier
- 10 Fan module
- 11 Seat spring

Fan modules for the seat surface and backrest

(here: seat surface)

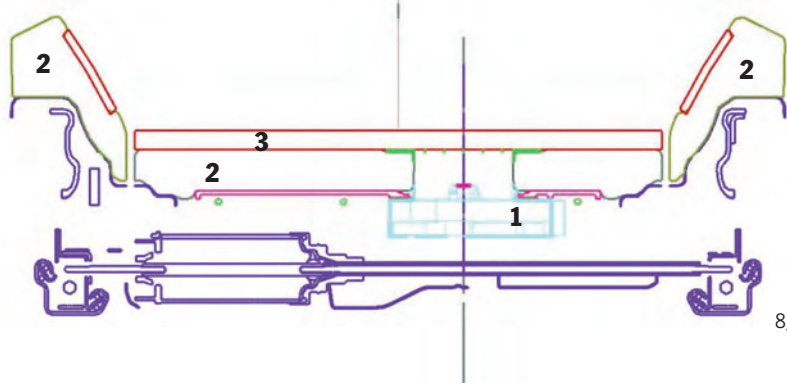

8_08_09

Air ducts for the seat surface and backrest

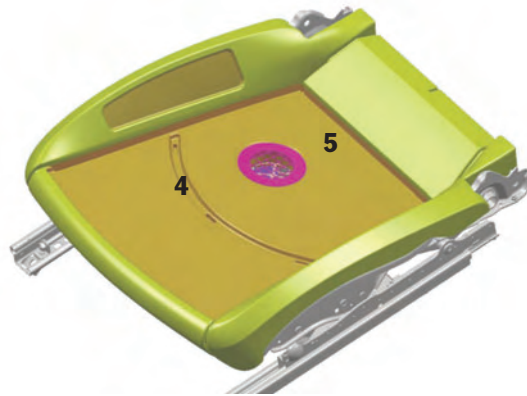

8_10_09

Air-permeable cushioned mats (here: seat surface)

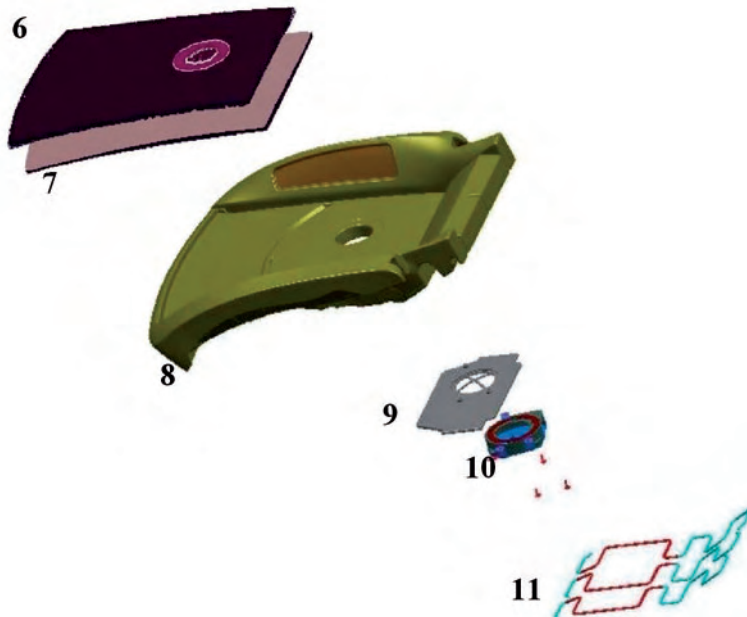

8_12_09

Heated steering wheel

General information

On all 2nd generation sports cars, the sports steering wheel for Porsche Doppelkupplung (PDK) as well as the optional multifunction steering wheels for Porsche Doppelkupplung (PDK) can come with steering wheel heating as an optional extra for greater comfort during the cold season.

Operating principle

Steering wheel heating can be switched on and off using a button on the 6 o'clock spoke of the steering wheel. When steering wheel heating is activated, the message "Steering wheel heating ON" appears for approx. 2 seconds on the on-board computer in the instrument cluster.

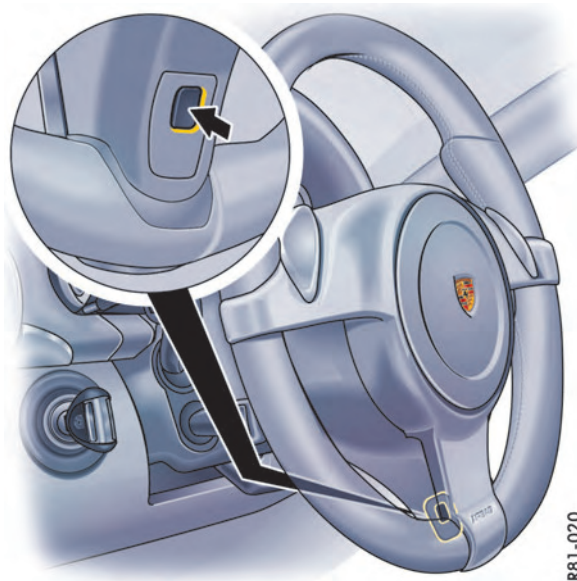

8_13_09

The interior temperature sensor in the automatic air-conditioner operating panel is used as the basis for controlling steering wheel heating. The heating time is temperature-controlled via a variable timer.

When this system is deactivated, the message "Steering wheel heating OFF" appears briefly on the on-board computer.



9 Electrics and electronics

Boxster
Boxster S
Cayman
Cayman S

Electrics und electronics

9

General information

The electrical systems used in the new 2nd generation Boxster/Cayman model series are essentially based on the first model generation. Relevant basic information can be found in the Technical Service Information for the Boxster/Boxster S, model year 2005 and for the Cayman S, model year 2006.

The following sections describe the specific features of the new 2nd generation Boxster/Cayman model series.

Lights

A completely new lighting generation in the area of the main headlights and front and tail light modules has been developed for the new Boxster and Cayman models:

- New halogen headlights with LED position light and fog lights
- Optional Bi-Xenon headlights with dynamic cornering light and LED daytime running lights, omitting fog lights
- Redesigned tail lights in LED technology

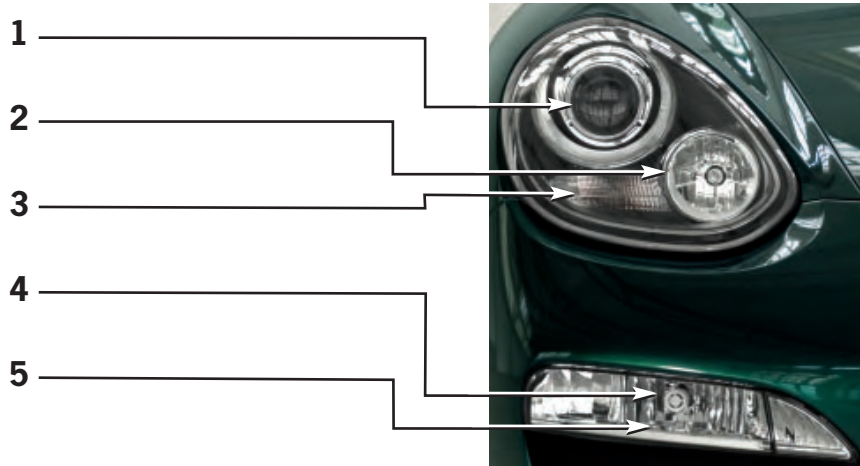

Boxster 9_01_09

Main headlight

- 1 Dipped beam headlight
- 2 High beam
- 3 Direction indicator

Front light module

- 4 Fog light
- 5 LED position light

General information, lights	157	Navigation module	174
Main headlights, front light module	158	Electronic logbook	176
Bi-Xenon headlight	159	Telephone module	177
Speed and swivel angle	162	Mobile phone preparation	178
Tail lights	162	Cordless handset	179
Instruments, instrument cluster	165	Voice control	179
Shift indicator	166	CD/DVD changer	180
Audio and communication, CDR-30	167	BOSE® Surround Sound System	180
Porsche Communication Management	169	Audio interface	182
Touchscreen and operating logic	171	TV tuner, satellite radio	183
Operating principles of PCM	173	Sport Chrono Package Plus	184
Audio	173		

Main headlights and front light module

The direction indicators are integrated into the main headlight module as before. The separate Boxster and Cayman front light modules, which are mounted into the respective external air intakes, include fog lights as standard. These are round on the Cayman and rectangular on the Boxster. On both models, a bright LED position light provides a characteristic additional light unit when the light is switched on.



Cayman 9_02_09



Boxster 9_03_09

Bi-Xenon headlight with dynamic cornering light and LED daytime running lights (optional)

Bi-Xenon headlights with dynamic headlight beam adjustment, dynamic cornering light, LED daytime running lights as well as headlight cleaning system are available as an option for the Boxster and Cayman. The clear glass design gives an unrestricted view of the sophisticated lighting technology with the dynamic cornering light. A horizontally arranged front light unit in a new design, incorporating the LED daytime running light and position light, is positioned above the front side air intakes. The LED daytime driving lights are designed as 6 LEDs on the Boxster and 4 LEDs on the Cayman. The position light on the models has 1 LED with a light guide. The LED daytime running lights replace the fog lights installed as standard. These fog lights are no longer needed because the Xenon dipped beam has been optimized to reduce scattered light and side-light output, thereby taking over the function of the fog lights. For dipped beam, the Bi-Xenon light offers approximately twice the light output compared to halogen headlights and good color vision due to a high color temperature.

Not all functions can be offered in all markets due to the different legal requirements. Unless prohibited by law in a specific country, the daytime driving light function is pre-set to “activated”, but can be deactivated at the request of the customer using the Instrument cluster menu. When the dipped beam is activated, the daytime driving lights are switched off automatically and the position light is activated.



Bi-Xenon on the Boxster 9_04_09



Bi-Xenon on the Cayman 9_05_09



The reduction of the scattered light and side-light output with Xenon means the fog lights are not needed with this version.

Innovative lighting technology: Bi-Xenon

Bi-Xenon lamps produce light based on the gas-discharge principle.

A spark discharge between two electrodes produces an "ionized gas tube" in the Xenon gas-filled lamp piston, through which electric current flows, which in turn causes the gas to light up. The longer service life of the Xenon system can be explained by the fact that the "arc" is less sensitive to mechanical loads than the bulbs used in halogen lamps.

Bi-Xenon headlights offer advantages both for dipped beam and high beam. They produce an intensive bluish light with a high illuminating power, which allows significantly better illumination of the road, particularly in bad weather conditions and in the dark.

Dynamic cornering light (optional)

The dynamic cornering light is offered for the first time for the Boxster and Cayman in combination with Bi-Xenon headlights. It is integrated into the new, striking inner styling of the double-lens projection system in the main headlights. The dynamic cornering light can be identified by the swivel mechanism at the inner headlight cover.

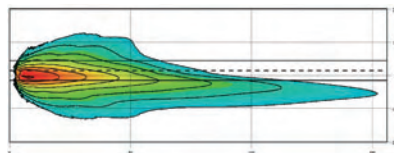

H7 headlight 9_06_09

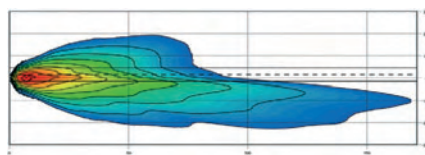

Bi-Xenon headlight when driving straight ahead 9_07_09

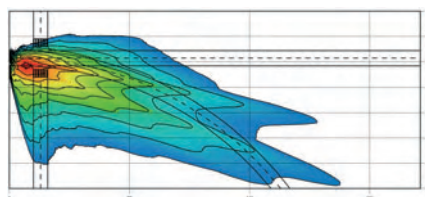

Bi-Xenon headlight when cornering 9_08_09

This technology improves active safety for night-time driving by providing optimal illumination in bends. The light beam is projected on to the road to a maximum range without dazzling on-coming traffic. When driving on twisting roads in the dark, on secondary roads or in protracted highway bends, the driver can see which way the road is going and detect any obstacles much earlier and can adapt his driving style accordingly.

The dipped beam in the Bi-Xenon headlights follows the driver's steering movements and continuously adjusts to the current driving speed. Sensors continuously record the driving speed as well as the steering angle, and use this information to "measure" the bend. A control unit uses the data it receives to work out the best angle for controlling the dynamic cornering light. The dipped beam is swivelled to the highest setting during cornering.

The dynamic cornering light is activated once the vehicle reaches a speed of 6 mph (10 km/h). The headlight adjustment angles depend on the vehicle speed and how sharply the driver turns the steering wheel. Viewed from the center axis of the vehicle, the maximum adjustment angle of the headlight at the inside of the bend is 15°, while the headlight angle at the outside of the bend is 7°. The different adjustment angles of the inside and outside light units ensure the widest possible illumination of corners because the two light beams do not focus their light on one point. The cornering light also remains active when high beam is switched on and therefore improves the driver's visibility. When the vehicle stops in a bend, the headlight swivel angle is adjusted slowly back to the zero position to produce a calm overall effect. The dynamic cornering light is not activated when reverse gear is engaged for legal reasons.



9_09_09



9_10_09

Speed and swivel angle

0 – 3 mph (0 – 5 km/h)	No swivel action.
Start-up: 3 mph (5 km/h) or faster	Headlights start to swivel, depending on the steering angle. Flat characteristic for smooth transmission. Headlights swivel by max. swivel angle of 11° for steering angle of 100° or more.
Residential area/ function start-up: 9 – 25 mph (15 – 40 km/h)	Headlight swivel angle increases continuously in line with steering angle (characteristics become steeper). Headlights swivel by max. swivel angle of 15° for steering angle of 90° or more.
City driving: 30 – 38 mph (50 – 60 km/h)	Objective: smooth action, e.g. both during cornering and for steering around parked vehicles.
Country roads/motorways: 45 mph (70 km/h) or faster	The swivel angles were increased slightly around the zero steering angle position for a more direct response to slight changes in steering angle.

Additional information on the cornering light – overview

- There is no swivel movement when the vehicle is stationary.
- When the vehicle stops in a bend, the headlight swivel angle is adjusted subtly back to the zero position to produce a calm overall effect.
- Not activated in reverse gear (prohibited by law).
- Swivelling occurs when the steering-wheel angle is between 0 and approx. 90°; no blind spot when the steering wheel is in central position, just a gentle transition.
- Swivel action also when high beam is switched on.
- Approx. $\alpha/2$ control with a swivel range of 15° outward and 7° inward (viewed from center axis of vehicle).

Tail lights

The redesigned tail lights in LED technology are not just a further visual highlight of the new Boxster and Cayman models, but also contribute actively to improving safety. The elegant and contoured shape of the tail lights blends perfectly into the respective designs of the new and unique Boxster and Cayman rear sections. Red and white (clear glass) functional areas give the lights a sporty look and the rear view a homogenous overall appearance.



9_11_09

The tail lights are designed as a single unit and combine the direction indicator, reversing light, brake light, position light, side marker light and reflector in one housing. The rear fog light is on the driver's side.



9_12_09

Apart from their new design, the most conspicuous feature of the new tail lights is the use of LEDs for rear and brake lights and for the rear fog light. As a result, it was possible to achieve a very striking night design.



Brake lights on the Cayman 9_13_09



Tail lights on the Cayman 9_14_09



Brake lights on the Boxster 9_15_09



Tail lights on the Boxster 9_16_09

The use of LED technology for the tail lights has the following advantages over tail lights equipped with ordinary bulbs:

- Response time is 1,000 times shorter
- Considerably longer service life (> 10,000 hours)
- Reduced energy consumption
- Better illumination
- Compact design

The much shorter response time of LEDs, in particular, contributes significantly to active safety on the road. While the response time of conventional bulbs is approx. 100 ms, the response time of LEDs is only approx. 0.1 ms. This difference is equivalent to a distance of almost 3 metres when travelling at 60 mph (100 km/h). Considerably earlier signalling of braking therefore provides a faster warning for traffic travelling behind. These can even be the decisive few yards that prevent a traffic accident. Earlier warning of traffic travelling behind is already achieved in the current Boxster and Cayman generation by the high-level 3rd brake light in LED technology. However, the additional use of LED technology in the two tail lights greatly reinforces this effect. The increased illumination of the LEDs compared to conventional bulbs also helps to provide a better warning for vehicles travelling behind.

Instruments/instrument cluster

The instrument cluster has been largely adopted from the previous generation. In order to harmoniously integrate the functions of the technical innovations on the new models into the vehicle interior, the following instruments, among others, have been enhanced:

- Display of the Porsche Doppelkupplung (PDK) shift pattern (P-R-N-D) as well as the manual operating position via LEDs. The engaged gear is displayed digitally
- Display of optimal shift point for an economical driving style (for manual transmission only)
- Activation of daytime running lights (optional) in the Instrument cluster menu



9_19_09

Shift indicator arrow

Shift indicator

For the first time, all new Boxster and Cayman models with manual transmission feature a shift indicator in the instrument cluster to reduce fuel consumption. In contrast to sporty shift indicators like on the 911 GT2 (and the last 911 GT3 models), for example, the new Boxster and Cayman models (like the new 911 models) feature an economical shift indicator.

The actual shift indicator lights up depending on the selected gear, engine speed and accelerator pedal position and prompts the driver to shift to the next-highest gear in order to reduce fuel consumption. The driver is only prompted to perform an upshift if the previously selected speed and acceleration can be continued in the next-highest gear. The actual display is located above the Porsche Doppelkupplung (PDK) shift pattern (P-R-N-D) in the shape of a triangle.

The PDK shift pattern display in the instrument cluster is based on the enhanced Tiptronic S concept. As for Tiptronic S, the engaged driving program is displayed via red LEDs next to the shift pattern in the instrument cluster. In addition, a large digital numeric display of the currently engaged gear appears to the left above the shift pattern display.

Audio and communication

CDR-30 audio system

Boxster and Cayman models are equipped as standard with an audio system with CD radio (CDR-30), 2 tweeters in the dashboard, 2 woofers in the door panels as well as 2 power amplifiers rated at 25 W each.

The other features are an FM double tuner with RDS diversity, a total of 30 memory locations, dynamic autostore and speed-dependent volume control.

The new radio can now also be operated using one of the optional multi-function steering wheels. There are also numerous components for the multimedia area available on request for the new Boxster and Cayman that can be tailored to the customers' needs.

Operating principles of the CDR-30



- 1 Main functions can be selected directly via function keys
- 2 A menu item is selected and activated
 - via **softkeys** or
 - via the rotary/push knob
- 3 Functions for the respective main selection can be called up via the **MENU button**
- 4 Press Back button (arrow) to go to the superordinate menu level

9_20_09

The following equipment versions are optionally available for the CDR-30:

Mobile phone preparation

- With Bluetooth® interface to connect a mobile phone to the Hands-free Profile (HFP). Includes the hands-free function and muting as well as operation of the basic functions via the CDR-30 or the multi-function steering wheel. Includes microphone, wiring and GSM external antenna.

Mobile phone preparation with console

- Additionally includes an attachment console on the side panel of the center console. For retrofitting a cradle.

Sound Package Plus, including CD storage box

- Analogue sound system including CD storage box in the glove box
- Model series-specific variants differ only in the number of channels
- Fully active system, i.e. all channels are actuated via amplifier (-> driver ICs are moved from the HU into the amplifier)
- Improved sound tuning options

BOSE® Surround Sound System, including CD storage box

- Digital sound system for a special audio experience, including active subwoofer and center speaker. 7-channel amplifier with a total output of 385 watts and BOSE® signal processing technology. Microphone for Noise Compression Technology for continuous optimisation of volume and tone. For a surround sound through Centerpoint™ signal processing technology.
- Cross-model series component
- Playback of DVD audio (5.1 Surround)

Integrated CD autochanger, 6-disc

- Integrated in the radio instead of the CD drive, including audio playback of MP3 music.

Universal audio interface

- iPod interface
- USB connection
- AUX interface

Rod antenna

- For improved medium wave reception

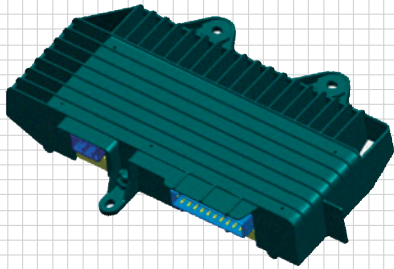

9_22_09

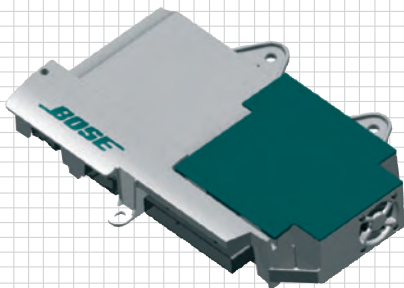

9_23_09

Porsche Communication Management (PCM) (optional)

The new 2nd generation Boxster/Cayman models can optionally be equipped with Porsche Communication Management (PCM 3.0). As the central control unit for all audio and communication equipment, it is now even more efficient, more versatile and easier to use. There are two types of PCM available – a Low or High system. The High system also includes a hard drive, navigation system and voice control (SBS).

The operating instructions provide comprehensive details of the wide range of functions available in each system. The high level of integration of the system, the large number of variants (just-in-sequence delivery in production) and the hard drive-based navigation system deserve special mention.



9_24_09

PCM 3.0 is much more compact than the previous system PCM 2.1. The CD autochanger, telephone module and navigation module systems, which were previously fitted separately in the vehicle, have been integrated into the PCM.

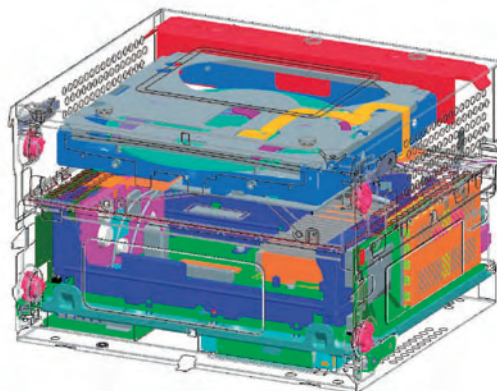

9_25_09

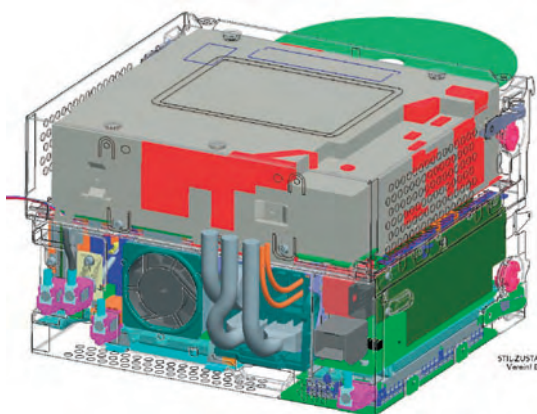

9_26_09

Upper part of chassis with DVD autochanger

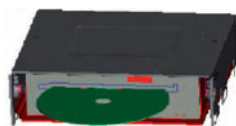

Upper part of chassis with single DVD

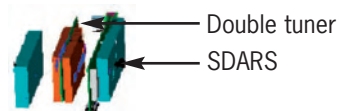

Sports car control panel



Lower part of chassis, basic

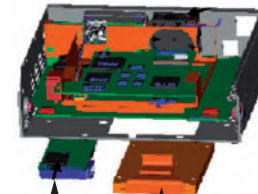

Telephone module HDD

9_26.1_09

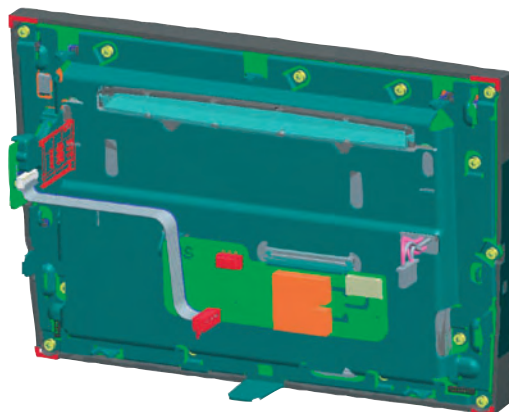

9_27_09



9_28_09

The touchscreen has a long-lasting, easy-to-clean coating. This protects the surface from marks and soiling from fingerprints.

By integrating the number pad into the touchscreen control panel, it was possible to significantly increase the diameter of the color screen from 5.8 to 6.5 inches compared to the last generation.

For greater clarity and ease of use, many of the key functions (hard keys) have been integrated into the touchscreen. It was therefore possible to reduce the number of hard keys by half from 32 to 16 compared to the previous model - without compromising on functionality. In addition, a number of functions that are rarely used were moved to a second menu level ("Option"). A maximum of five list entries are now displayed on each page - giving a much clearer screen display that is considerably easier to read.

An intelligent Help function with operating instructions in the footer of the screen provides added support for users in many situations, e.g. for storing radio stations or inserting CDs into the internal autochanger.

Operating principles of PCM 3.0



9_29_09

- 1 Main functions can be selected directly via function keys
- 2 A menu item is selected and activated
 - via the rotary/push knob or
 - via the **touchscreen**
- 3 Select **OPTION** to display management functions or specific options for the current display in a context menu
- 4 Press Backbutton (arrow) to go to the superordinate menu level

Audio

The heart of the integrated radio module is an FM double tuner with RDS, a total of 48 memory locations for FM and medium wave stations and the latest generation of the diversity function: the system constantly searches for the best frequency of the selected station in the background, and up to four FM radio antennas are interconnected as required for optimal reception (Scan & Phase Diversity).

The operating principle is the same as for the previous model.

The integrated drive plays music from CDs and now also from audio and video DVDs – even in 5.1 Discrete Surround Format with the BOSE® Surround Sound System, otherwise in stereo. The following formats are supported: MP3, AAC, WMA, Dolby Digital, MLP and DTS.

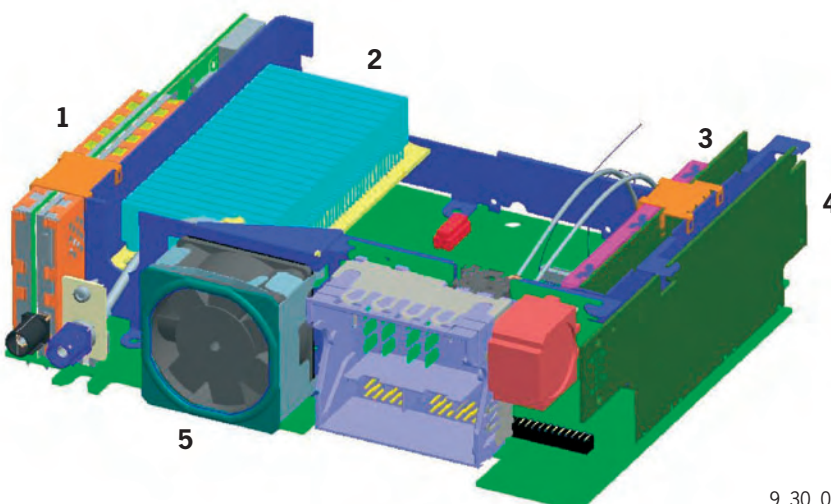

9_30_09

- 1 FM/AM tuner
- 2 Digital tuner SDARS (XM)
- 3 Power
- 4 I/O gateway
- 5 Fan

Navigation module (optional)

Navigation in the new PCM 3.0 is performed for the first time via an integrated 40-GB hard drive, on which data for most countries in a specific region is stored (e.g. Europe, North America, Middle East). This guarantees considerably faster route calculation – users can get the system to calculate three alternative routes.

The large touchscreen allows users to enter destinations quickly and easily. Current information on traffic jams or special points of interest (POIs) can be displayed by simply touching the symbols on the map. Intermediate destinations or stop-off points, e.g. the nearest service station or restaurants, can now be added quickly and easily to active route guidance.

The map view shows the height profile. It can also be viewed in perspective or as a normal two-dimensional display. The scale of the map is adjusted continuously when the entire route is displayed. As a result, the remaining distance from the vehicle position to the destination flag is shown at maximum enlargement. Additional graphic turn-off instructions can also be displayed for better guidance for highway exits.



9_31_09

In split-screen mode, a list of the next manoeuvres the driver must make can be displayed in the form of pictograms beside the current map view, for example.



9_32_09

The familiar enhanced functions have been adopted: route guidance along a previously recorded route (Backtrace Navigation/option) as well as navigation in non-digitally recorded areas using a compass and GPS are also supported. Additional weight saving compared to the previous model was achieved for the optional equipment by removing the previous external DVD navigation drive in the luggage compartment. When the optional TV tuner is ordered, a luggage-compartment cooling system assigned to navigation is installed in areas with particularly high temperatures.

Electronic logbook (optional)

The electronic logbook is still offered in conjunction with the navigation module. It is used for automatically recording the mileage, distance travelled, date and time as well as the start and destination address for each trip.

There are now two ways of reading out data: either using the standard Bluetooth® interface for PCM or via USB together with the universal audio interface. The data can be evaluated on a home PC using the included software.



9_33_09

Telephone module (optional)

The internal GSM telephone module, which is available on request, offers optimised sound quality and is extremely easy to use. As a quad-band telephone module (for GSM networks 800, 900, 1800 and 1900), it now covers all GSM frequency ranges currently used worldwide.



9_34_09

The hands-free quality has been improved significantly in the new generation. Two circular microphones in the steering column cover are switched together using beamforming technology. As a result of the continuous measurement and weighting of the various sound signals (useful signal = voice, interference noises = wind noise, engine noise, for example), the signals that are received are directed more towards the driver and reception quality is optimised. Weighting is performed according to direction, i.e. the shorter the time delay, the more likely the driver's position is the source of the signal. This innovative technology is particularly effective at filtering out and eliminating interfering signals.

Essentially, two alternative operating modes are possible:

1. With SIM card inserted

A SIM card can be inserted into the SIM card reader integrated in PCM in the usual way and calls can be made and received using the hands-free facility or the cordless handset, which is available on request.

2. Using Bluetooth® (SAP)

The excellent hands-free quality of the telephone module also comes in handy in this mode with the added convenience of not having to insert a SIM card: the mobile phone you are carrying connects automatically to the telephone module via a Bluetooth® connection using the SIM Access Profile (SAP). Virtually all telephone functions are performed via Bluetooth® without a cable connection regardless of whether the mobile phone is in the console or somewhere else inside the vehicle, e.g. in a jacket pocket.

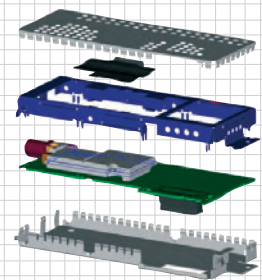

9_35_09

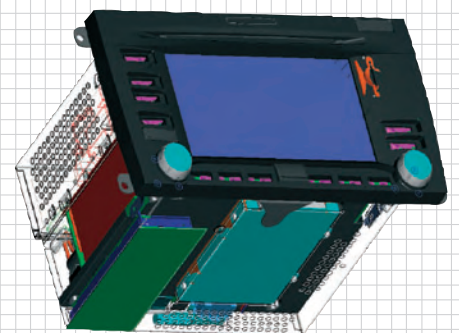

9_36_09



A list of mobile-phone brands compatible with Bluetooth® can be found at www.porsche.com (vehicle selection\convenience).

Having connected once, the PCM system detects your mobile phone whenever you get into the vehicle and connects again automatically. Up to five different mobile phones can be stored in this way.

The mobile phone antenna is switched off to save the battery and only the vehicle's external antenna is used for making and receiving calls. It is possible not only to access the data on the SIM card, but also the telephone numbers in the internal memory, depending on the type of mobile phone.

Calls can be made and received completely via the PCM, the multi-function steering wheel or voice control - while your mobile phone stays comfortably in your jacket pocket.

Mobile phone preparation (optional)

The telephone module is the best solution for customers with a GSM Bluetooth® SAP mobile phone. Alternatively, a mobile phone preparation is available on request. With this optional equipment, even GSM or CDMA mobile phones, which only support the Hands-free Profile (HFP), can be used via a convenient Bluetooth® telephone solution.

When connected via the hands-free profile, PCM is used only as a hands-free facility. Again, your mobile phone stays comfortably in your jacket pocket – the telephone numbers are copied either one-by-one or as a complete list into the PCM system, depending on the type of mobile phone. The basic mobile phone functions can be controlled via the PCM, the multi-function steering wheel or via voice control. GSM is always connected via the mobile phone antenna.

The use of a mobile phone inside the vehicle increases the strength of electromagnetic fields and can therefore expose the passengers to radiation. The PCM telephone module prevents this type of exposure because the vehicle's external antenna is always used. An upgrade kit (cradle), which is available for many mobile phones in independent accessory stores, allows users to use the external antenna and charge the mobile phone battery via the mobile phone preparation.

A console for this available as a factory installed option. The console reduces antenna radiation inside the vehicle and is a convenient way of charging the mobile phone. All other telephone functions are performed via Bluetooth®.

Two different types of mobile phone preparation are available: the first type includes an attachment console on the side panel of the front right center console for retrofitting a mobile phone holder. Since not all customers who buy the mobile phone preparation will retrofit a mobile phone holder at a later stage, it is also available without the console for an improved look and to reduce weight.

Cordless handset for telephone module (optional)

A cordless (Bluetooth®) handset is available together with the telephone module. This replaces the previous PCM handset. The handset is colour-coordinated to suit the instruments and has its own display as well as its own keypad for making and taking discrete telephone calls inside the vehicle. It also includes a holder with leather trim on the side panel of the front right centre console and a charging tray on which the handset sits securely and is always clearly visible and within easy reach of the driver.

Voice control (optional)

A voice control system with whole-word input is available in conjunction with the new hard drive navigation. This system is state-of-the-art and offers relaxing and controlled driving comfort. Your hands can stay on the steering wheel and your eyes on the road. For details of the comprehensive range of options available in the system, see the operating instructions. Here is an overview of the most important functions:

- Voice control is activated by pressing the button on the lower steering-column lever at the left. Almost all PCM functions are now voice-controlled.
- The system is designed so that each menu item can generally be spoken just as it appears on the screen. Commands or number sequences are recognised regardless of who actually speaks. The system does not have to be taught.
- Voice control guides the user interactively through the functions and outputs acoustic feedback. Context-specific lists with possible voice commands are also displayed on the screen.



9_37_09



9_38_09

Calls based on phone book entries, switching radio stations or entering country, city and street destinations – all this is now performed directly by speaking whole words. The system has a high recognition rate. For example, if the city is not recognized immediately in individual cases, the system displays a readable list of possible city names that are phonetically similar. This list is numbered, which means that you can continue simply by speaking the relevant number.

The new voice control system is much more convenient and ensures greater safety, particularly when operating the navigation system and the telephone module.

6-disc CD/DVD autochanger (optional)

A 6-disc CD/DVD autochanger, which is integrated into the PCM, is also available instead of the standard single CD/DVD drive. It is located for the first time within easy reach of the driver and like the single CD/DVD drive, it also supports a variety of formats: a significantly more convenient system. CDs/DVDs can be loaded and ejected one at a time via the PCM slot after first selecting the changer number.

The removal of the CD autochanger from the luggage compartment has advantages not only with regard to weight, but also with regard to loadspace volume, since it was located at the side of the luggage compartment.

BOSE® Surround Sound System (optional)

The BOSE® Surround Sound System is developed specifically for Porsche and is optimally adapted to the new Boxster/Cayman models. A total of 11 (Boxster) or 12 loudspeakers (Cayman), including an active subwoofer and centre speaker as well as a 7-channel digital amplifier guarantee an impressive audio experience. The rated power of the amplifier is 385 watts.

When playing music from audio or video DVDs, the system opens up the impressive audio spectrum of digital 5.1 recordings. The sound of music in 5.1 format is already recorded in multi-channel format and the original information remains uncorrupted during playback.

Five full-size audio channels (front left, front right, centre, surround left, surround right) and one effect channel for low frequencies provide authentic and natural stereophonic sound: Discrete 5.1 Surround Sound with voices and effects that can be located precisely from front and rear. The audio experience is the next best thing to a live performance with cinema-quality sound similar to what you get from a very sophisticated home cinema system.

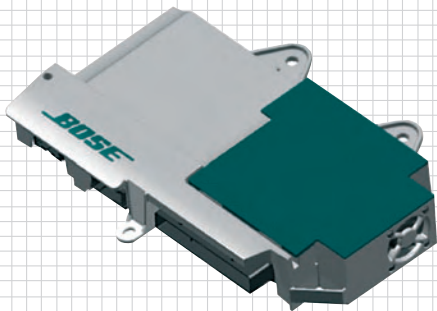

9_39_09

Stereo sources, such as CDs, are played in a Surround mode, which is generated by the patented BOSE® Centerpoint® technology. The new Centerpoint® II algorithm extracts an even more precise and realistic stereophonic sound from the stereo signal.

SurroundStage® signal processing developed by BOSE® assigns each individual audio channel, whether from a DVD or generated through Centerpoint®, to a selected combination of loudspeakers, thereby always ensuring optimally balanced surround sound for all seats.

In addition to high-quality stereophonic sound simulation, the extensive audio tuning capability of the BOSE® Surround Sound System offers perfectly attuned sound in every situation: as early as the development stage, sound reproduction was adapted exactly to the specific interior acoustics of the new Boxster/Cayman models. The dynamic Loudness function raises the bass sounds as the volume drops and thus compensates for the lowered sensitivity of the human ear at these frequencies. In addition, the AudioPilot® Noise Compensation Technology continually measures all sounds inside the vehicle using a microphone and auto-matically adapts the music that is playing to achieve a balanced sound in all driving situations.



9_40_09



9_41_09

Universal audio interface (optional)

The optional universal audio interface makes it possible for the first time to connect an external audio source, e.g. an iPod® or a USB stick, and use it conveniently via the PCM system.



9_42_09

There are three connection points in the storage tray in the center console:

1. iPod® interface and connecting cable for connecting and charging various iPod® models (iPod® 4th generation, iPod® 5th generation (video), iPod® nano, iPod® nano 2nd generation, iPod® mini and iPod® photo). It is also possible to connect the Apple iPhone®, which can be connected to the PCM at the same time via Bluetooth® HFP in order to use the hands-free facility (only in conjunction with mobile phone preparation).
2. USB connection for USB memory sticks with MP3 music. An iPod® or a USB memory stick can be used safely and conveniently via the PCM, the multi-function steering wheel or voice control. The USB connection can also be used to download performance display data for the Sport Chrono Package Plus (optional) as well as electronic logbook data (optional).
3. AUX interface for connecting other external audio sources. The basic functions can be used via PCM, the multi-function steering wheel or voice control.

TV tuner (optional)

The TV tuner receives unencrypted analog (PAL, Secam and NTSC) and digital (DVB-T) TV signals. For safety reasons and to comply with legal regulations, only sound output is possible while driving. Depending on the legal requirements in the relevant countries, the exact speed limit for switching off the display is between 0 and 5 km/h (3 mph). The electronic programme guide (EPG) and teletext can also be displayed, depending on availability. Please read the instructions for use and the repair instructions in PIWIS.

Satellite radio (Satellite Digital Audio Radio Services/SDARS) for USA (optional)

The digital satellite radio SDARS from the provider XM is available for USA/Canada. This opens up an extensive range of music, sport, entertainment and information stations for customers, with approx. 170 channels in USA and approx. 130 channels in Canada at present. After a free, 3-month trial period, customers can opt to continue using the XM service by paying a certain subscription.

The discrete antenna for satellite radio (in the vehicle's exterior colour) is positioned centrally: on the hood compartment lid on the Cabriolet and on the back of the roof on the Coupé. As a result, the optional rod antenna for improved terrestrial medium-wave reception is now always fitted on the wing at the front right.



9_43_09

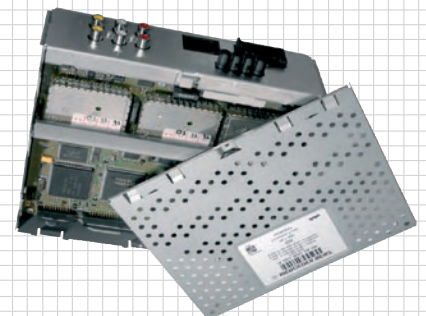

9_44_09

Sport Chrono Package Plus (optional)

As on the previous models, a Sport Chrono package is offered as an option in combination with the CDR-30 radio and a Sport Chrono Package Plus is offered as an option in combination with Porsche Communication Management (PCM) on the new Boxster and Cayman models. Both packages contain the familiar features:

- Analog stopwatch on the dashboard
- Sport mode for engine, optional PASM and PSM incl. SPORT button for activation

In combination with Porsche Communication Management (PCM), the Sport Chrono Package Plus also contains the following features:

- Performance display in the instrument cluster
- Personal memory

The introduction of an additional SPORT PLUS button in conjunction with Porsche Doppelkupplung (PDK) is completely new in both packages. Actuating this button allows uncompromisingly sporty gearshifts for maximum performance on race tracks. In addition, the Launch Control assistance system can be activated for best possible drive-off acceleration in this driving program. The new additional features offer the customer a significantly enhanced overall package for further improved lap times as well as increased vehicle agility and greater driving pleasure. For further information, see the section Porsche Doppelkupplung (PDK).

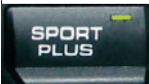

9_45_09

	MY 2008		MY 2009		
	Manual transmission	Tiptronic S	Manual transmission	PDK	
Switch panel	Analogue stopwatch	Analogue stopwatch	Analogue stopwatch	Analogue stopwatch	in the PCM
	Performance display*	Performance display*	Performance display*	Performance display*	
	Individual memory	Individual memory	Individual memory	Individual memory	(light, wiper, air conditioning and door locks)
	- Activation of sport mode for -				
	- Engine	- Engine	- Engine	- Engine	
	- Sports exhaust system**	- Sports exhaust system**	- Separate switch	- Separate switch	
	- PSM	- PSM	- PSM	- PSM	
	- PASM**	- PASM**	- PASM**	- PASM**	
		- Tiptronic S		- PDK	
				- Activation -	
				- Launch Control	
				- PDK (racing circuit mode)	



9_46_09

* Additional features for Sport Chrono Package Plus

** Additional options

New features are shown in **bold**



**WE SUPPORT
VOLUNTARY TECHNICIAN
CERTIFICATION THROUGH**

National Institute for
**AUTOMOTIVE
SERVICE
EXCELLENCE**

